

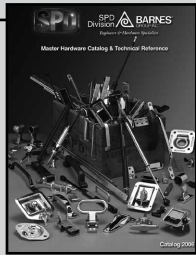

2012 CATALOG
COUNTERBALANCE SOLUTIONS

In addition to the products described in this catalog, Associated Spring Raymond— a worldwide leader in the design, manufacture and sale of springs — also offers a full line of struts, hardware, tool & die components:



SPD Division
Struts and hardware catalog



SPEC Precision Engineered Components
Stock springs, spring washers & retaining rings

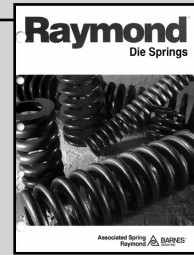

Raymond Die Springs
Inch dimensions & US standard

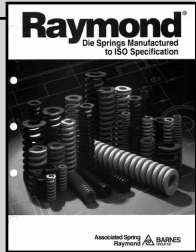

Raymond Die Springs
Manufactured to ISO 10243 specification

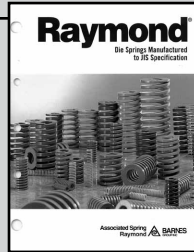

Raymond Die Springs
Manufactured to JIS B 5012 specification

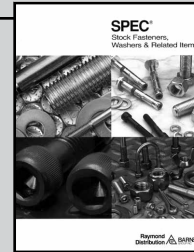

Raymond SPEC Stock Fasteners, Washers & Related Items
A complete line of stock fasteners and washers

CALL US AT 1-800-228-1156 FOR TECHNICAL ASSISTANCE OR TO RECEIVE OUR COMPLETE CATALOGS OF SPECIFICATIONS.

New in our SPEC Catalog for 2011: Extension and Torsion Springs in 316 Stainless Steel Compression Springs in Inconel® X750 Expanded Gas Strut lines

Associated Spring Raymond now offers complete lines of 316 Stainless Steel Extension and Torsion springs, and a range of Compression Springs in Inconel X750. Both materials offer superior temperature and corrosion resistance, which make them particularly suitable for:

- Medical, surgical, veterinary and pharmaceutical applications
- Food and food preparation machinery and equipment
- Aircraft, aerospace and nuclear reactor uses
- Gas turbines and pressure vessel applications
- Harsh environment projects

Our Gas Strut lines now include expanded Black Nitride offerings as well as new Welded Blade Ends and Damper units.



Click on the links at right to navigate to the corresponding pages.

R12	4
EP2 16	5
EP2 24	6
EPS2 24	7
R19	8
M2	9
Powerline X 170	10
CU 420	11
Powerline X 320	12
Powerline X 350	13
TU 250	14
TM/TI 250	15
CU 740	16
Powerline X 500	17
TU 500	18
Powerline X 750	19
TU 750	20
CU 1000 - 1800	21
X 1000 and XMS 1000	22
Powerline X 1500	23
Powerline X 2400	24
TU 1500	25
CU 2900	26
CU 4700	27
Powerline X 4200	28
TU 3000	29
Powerline X 6600	30
TU 5000	31
CU 7500	32
Powerline X 9500	33
TU 7500	34
CU 11800 - 18300	35
TU 10000	36
Overview - Automotive Standards	37
Mechanical Compression Spring Struts	38-41
Mechanical Spring Struts Capabilities	42-45
GSNI Black Nitride Shaft Gas Spring, The Nitrider™ !	46-55
GSGT Multi-Range Gas Spring, The Multi Stop™!	55
GSSX Stainless Steel Gas Springs	56-64
GSEL Shock-Lock™ Gas Springs	65-66
GSVL Varilift Gas Springs	66
How To Specify End Fittings	67
GSBL Adjusta-Lock Gas Springs	67
Standard Dampers	68-70
GSWB Welded Blade End Gas Springs	71-77
TSNI Traction Gas Springs	78-79
Gas Spring End Fittings	80-81
Rod End Bearings	81
Gas Spring Mounting Hardware	82-88
Hardware Kits	89
Terms of Sale	90



We are also
ISO/TS 16949:2009
Certified

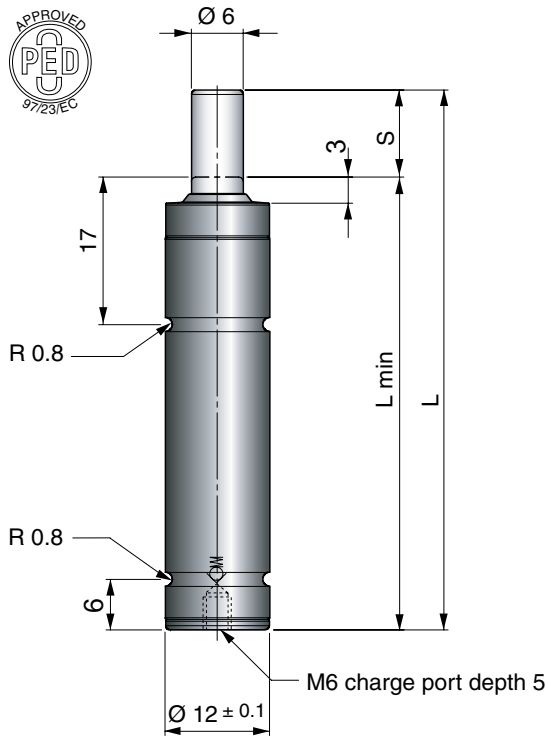

R12 gas springs are available in four pre-charged models. All R12s are adjustable by the end user. Black is used to denote charging pressures in between or below the standard color pressure codes.

An upper and lower C-groove together with threaded bottom hole allow various mounting possibilities using the new FCR-12 flange mount.

R12 gas springs can be hoses together using the M6 port and Micro-Hose™ system.

Model	Pounds Force (lbF) at +20°C	Color	Charging Pressure (psi)	Pounds Force (lbF) at +20°C at full stroke
	Initial			
R12	29	Green	652	40
R12	56	Blue	1279	81
R12	85	Red	1958	121
R12	112	Yellow	2610	164
R12*	13-112	Black	290-2610	19-164

S Stroke	L ±0.25	L min	Gas vol. [l]	Weight [kg]
7	56	49	0.001	0.03
10	62	52	0.001	0.03
12.7	67.4	54.7	0.001	0.03
15	72	57	0.002	0.03
19	80	61	0.002	0.04
25	92	67	0.002	0.04
38	118	80	0.003	0.04
50	142	92	0.004	0.05
63.5	172	108.5	0.005	0.06
75	195	120	0.006	0.06
80	205	122	0.006	0.07
100	245	145	0.008	0.07
125	295	170	0.010	0.09

* User specified charge pressure.

How to order

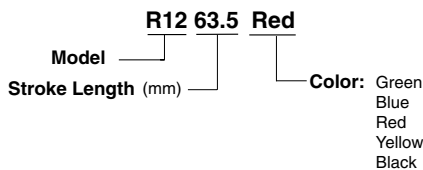

BASIC INFORMATION

Pressure medium Nitrogen
 Max. charging pressure 180 bar/2610 psi
 Min. charging pressure 20 bar/290 psi
 Operating temperature 0 - 80°C/ 0 - 176°F
 Force increase by temperature ±0.3%/°C
 Recommended max strokes/min ~40-100 (at 20°C)
 Max piston rod velocity 1.6 m/s
 Rod surface Nitrided
 Tube surface Black oxide
 Not repairable

MOUNTING POSSIBILITIES

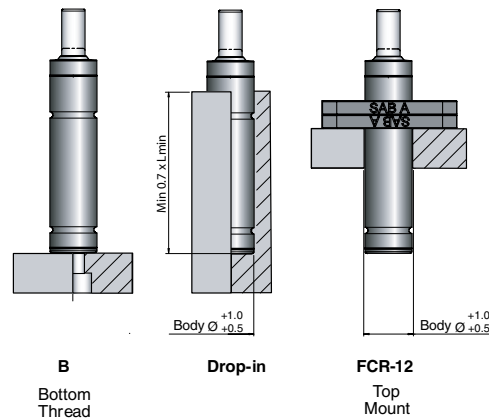

FCR-12
 Order No: FCR-12

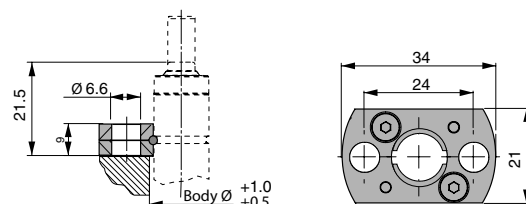

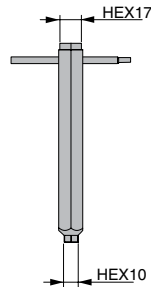
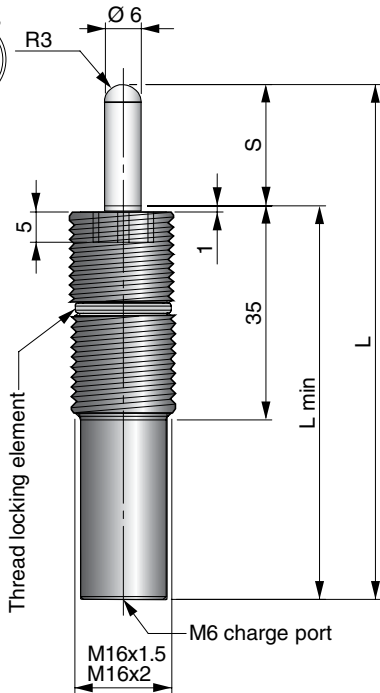

EP2 16/24
Installation Tool,
Order No. 3021000

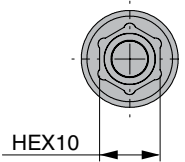

Millimeters to Inches: $mm \div 25.4 = \text{inches}$
 Kilograms to Pounds: $Kg \div 0.45 = \text{pounds}$
 Pounds Force to DecaNewtons:
 $LbF \times 0.4448 = \text{decaNewtons}$

EP2 16 gas springs (Ejector Pin with an M16 thread) are available in M16x1.5 and M16x2 thread sizes.

In each thread size, five models are available. Four preset models (Green, Blue, Red & Yellow) and one adjustable model (Black).

They are all color-coded to help identify the force rating and can be adjusted and recharged to meet individual force requirements.

How to order

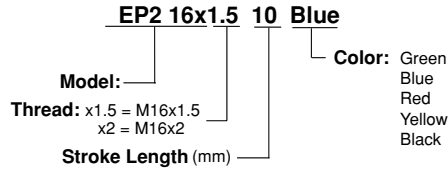

Model	Pounds Force (lbF) at +20°C		Color	Charging pressure (psi)	End Force in Pounds (lbF) at +20°C, at full stroke
	Initial				
EP2 16	13		Green	290	20
EP2 16	25		Blue	580	40
EP2 16	47		Red	1015	100
EP2 16	95		Yellow	2175	150
EP2 16*	13-95		Black	87-2175	20-150

* User specified charge pressure.

S Stroke	L ±0.25	L min	Gas vol. (l)	Weight (kg)
10	65	55	0.002	0.06
20	85	65	0.003	0.07
30	105	75	0.003	0.07
40	125	85	0.004	0.08
50	145	95	0.005	0.08
60	165	105	0.006	0.09
70	185	115	0.007	0.10
80	205	125	0.008	0.11
100	245	145	0.009	0.11
125	295	170	1.012	0.13

BASIC INFORMATION

- Pressure medium Nitrogen
- Max. charging pressure 150 bar/2175 psi
- Min. charging pressure 6 bar/87 psi
- Operating temperature 0 - 80°C/0 - 176°F
- Force increase by temperature ± 0.3%/°C
- Recommended max strokes/min..... ~ 100 (at 20°C)
- Max piston rod velocity..... 1.6 m/s
- Rod surface Nitrided
- Tube surface Black Oxide
- Not repairable

MOUNTING POSSIBILITIES

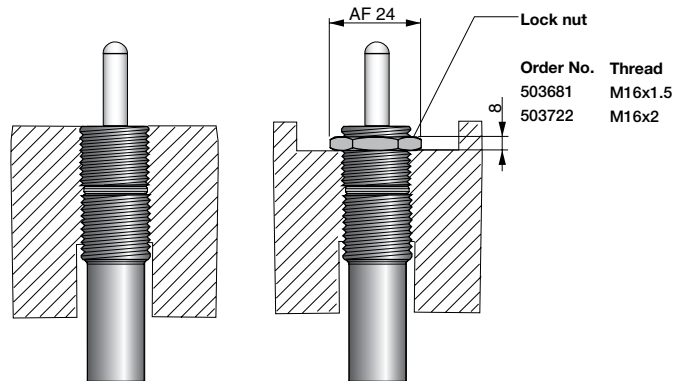

We reserve the right to add, delete or modify components without notification.

All dimensions are stated in mm.

All dimensions are nominal unless tolerance is stated.

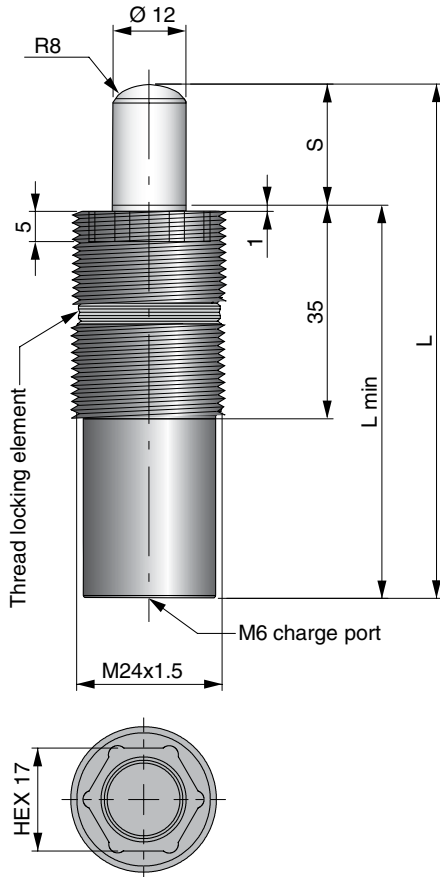

EP2 24 (Ejector Pin with an M24 thread) is available with four pre-set models. Each model is color-coded for easy identification of force rating. If needed, these models can be recharged or adjusted to meet individual force requirements.

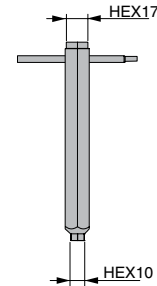

EP2 16/24 Installation Tool,
Order No. 3021000

How to order

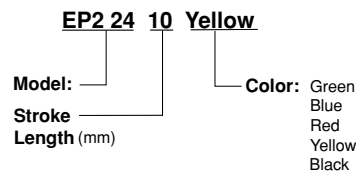

Model	Pounds Force (lbF) at +20°C		Charging pressure (psi)	End Force in Pounds (lbF) at +20°C, at full stroke
	Initial	Color		
EP2 24	52	Green	290	90
EP2 24	101	Blue	580	180
EP2 24	191	Red	1015	340
EP2 24	382	Yellow	2610	650
EP2 24*	52-382	Black	87-2610	25-650

* User specified charge pressure.

S Stroke	L ±0.25	L min	Gas vol. (l)	Weight (kg)
10	65	55	0.05	0.13
20	85	65	0.07	0.15
30	105	75	0.10	0.17
40	125	85	0.12	0.19
50	145	95	0.14	0.21
60	165	105	0.17	0.23
70	185	115	0.19	0.25
80	205	125	0.22	0.27
100	245	145	0.26	0.31
125	295	170	0.32	0.35

BASIC INFORMATION

Pressure medium Nitrogen
 Max. charging pressure 180 bar/2610 psi
 Min. charging pressure 6 bar/87 psi
 Operating temperature 0 - 80°C/0 - 176°F
 Force increase by temperature ± 0.3%/°C
 Recommended max strokes/min..... ~ 30-80 (at 20°C)
 Max piston rod velocity..... 1.6 m/s
 Rod surface Nitrided
 Tube surface Black Oxide
 Not repairable

MOUNTING POSSIBILITIES

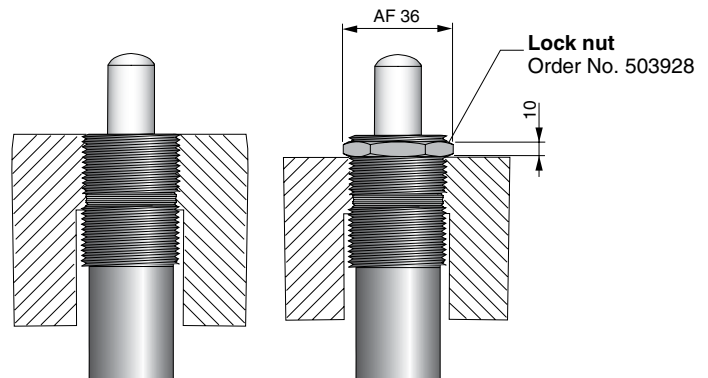

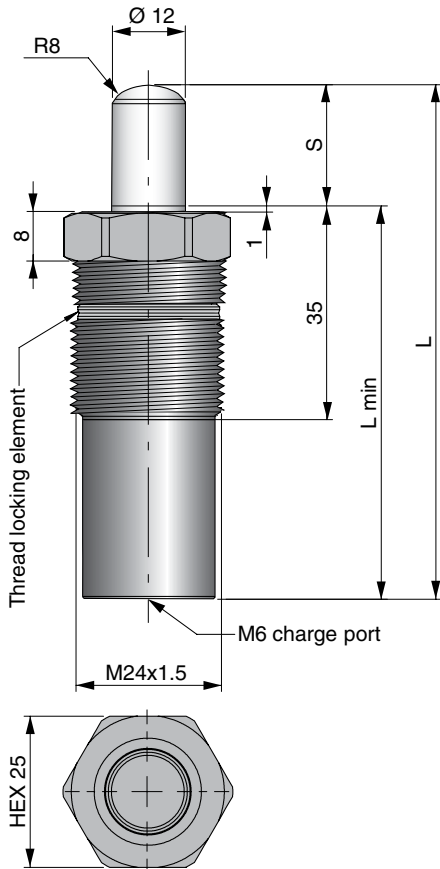

EPS2 24 (Ejector Pin Special with an M24 thread) is available with four pre-set models. Each model is color-coded for easy identification of force rating. If needed, these models can be recharged or adjusted to meet individual force requirements.

Also available is a model (black) which is delivered with a precharge of 73-140 psi, intended to be adjusted to the desired force.

The EPS2 24 is based on FORD's WDX3580-19XX XX XX gas spring standard.

Millimeters to Inches: mm ÷ 25.4 = inches
Kilograms to Pounds: Kg ÷ 0.45 = pounds
Pounds Force to DecaNewtons: LbF x 0.4448 = decaNewtons

Model	Pounds Force (lbF) at +20°C		Charging pressure (psi)	End Force in Pounds (lbF) at + 20°C, at full stroke
	Initial	Color		
EPS2 24	52	Green	290	90
EPS2 24	101	Blue	580	180
EPS2 24	191	Red	1015	340
EPS2 24	382	Yellow	2610	650
EPS2 24*	52-382	Black	87-2610	25-650

* User specified charge pressure.

How to order

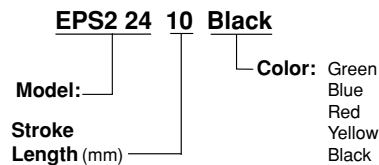

S Stroke	L ±0.25	L min	Gas vol. (l)	Weight (kg)
10	65	55	0.05	0.15
16	77	61	0.06	0.16
20	85	65	0.07	0.17
25	95	70	0.08	0.18
30	105	75	0.10	0.19
38	121	83	0.11	0.21
40	125	85	0.12	0.21
50	145	95	0.14	0.23
60	165	105	0.17	0.25
70	185	115	0.19	0.27
80	205	125	0.22	0.29
100	245	145	0.26	0.33
125	295	170	0.32	0.37

BASIC INFORMATION

- Pressure medium Nitrogen
- Max. charging pressure 180 bar/2610 psi
- Min. charging pressure 6 bar/87 psi
- Operating temperature 0 - 80°C/0 - 176°F
- Force increase by temperature ± 0.3%/°C
- Recommended max strokes/min..... ~ 30-80 (at 20°C)
- Max piston rod velocity..... 1.6 m/s
- Rod surface Nitrided
- Tube surface Black Oxide
- Not repairable

MOUNTING POSSIBILITIES

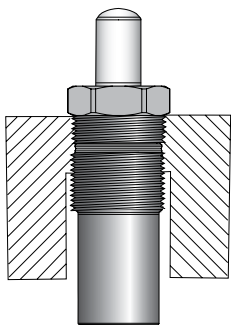

We reserve the right to add, delete or modify components without notification.
 All dimensions are stated in mm.
 All dimensions are nominal unless tolerance is stated.

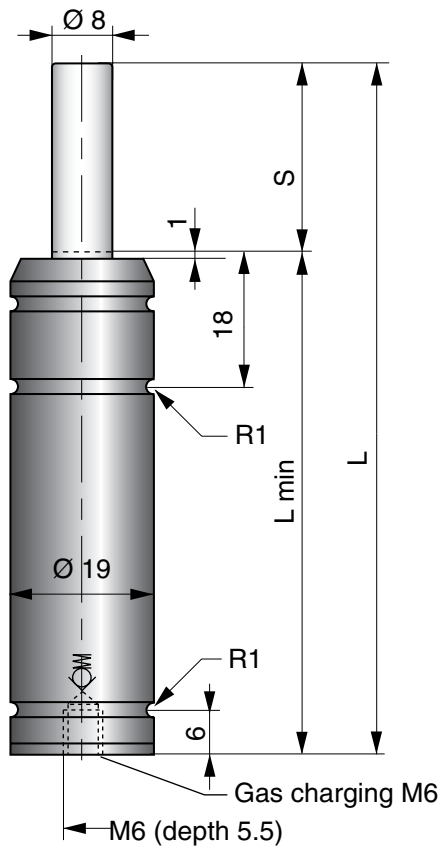

The R19 Gas Springs are available in four preset models. Each spring is color-coded for easy identification of force rating.

The R19 is rechargeable but cannot be rebuilt as the spring body is roll formed around the internal components.

There are two types of mountings for the R19: the BF 19 used at the lower body groove location and the FCR 19 used at the upper groove. The M6 thread in the base of the spring is used for filling and is also a mounting option.

How to order

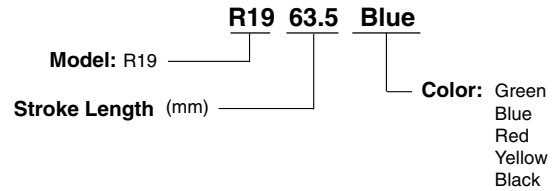

Model	Charging pressure (psi)	Color	Pounds Force (lbF)
			Initial
R19	870	Green	67
R19	1450	Blue	112
R19	2030	Red	157
R19	2610	Yellow	202
R19*	650-2610	Black	67-202

* User specified charge pressure.

S Stroke	Pounds Force (lbF) at full stroke				L ±0.25	L min
	R19 Green	R19 Blue	R19 Red	R19 Yellow		
7	119	199	270	360	56	49
10	105	175	247	315	62	52
15	99	164	225	292	72	57
25	94	157	220	292	92	67
38	92	155	218	270	118	80
50	92	152	216	270	142	92
63.5	92	152	214	270	169	105.5
80	92	152	214	270	202	122
100	92	152	214	270	245	145
125	92	152	214	270	295	170

BASIC INFORMATION

Pressure medium Nitrogen
 Max. charging pressure 180 bar/2610 psi
 Min. charging pressure 45 bar/650 psi
 Operating temperature 0 - 80°C/0 - 176°F
 Force increase by temperature ± 0.3%/°C
 Recommended max strokes/min..... ~ 100-150
 Max piston rod velocity..... 1.6 m/s
 Tube Black oxide
 Not repairable

MOUNTING POSSIBILITIES

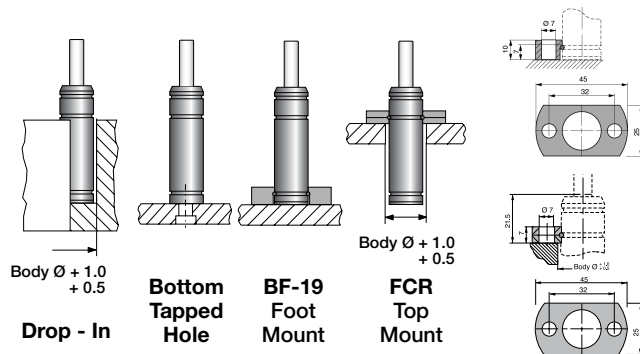

A business of BARNES GROUP INC

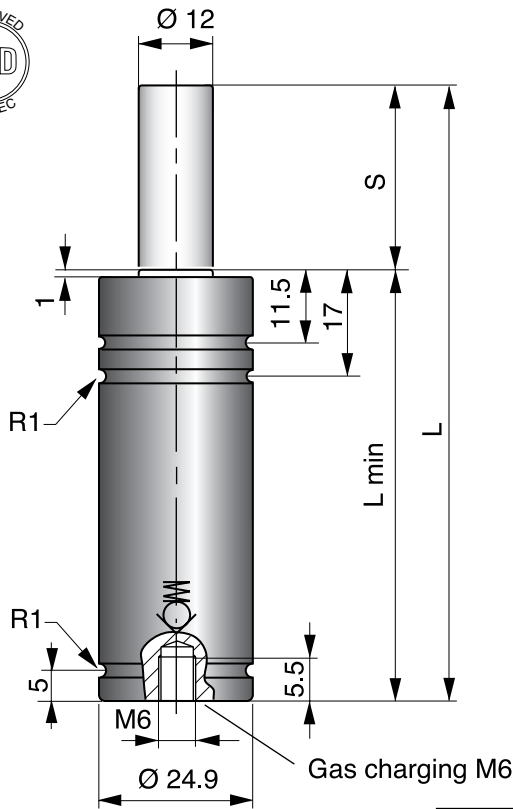

The M2 is available in four preset models, with initial forces from 110 to 450 lbF. Each spring is color-coded for easy identification of force rating.

The M2 spring can in many cases directly replace mechanical die springs of 25 mm (1 inch) diameter.

All M2 springs can be repaired and recharged.

The spring can be used attached to the tool, using a mount (FCR or SM). The M6 thread in the base of the spring is used for filling and is also a mounting option.

How to order

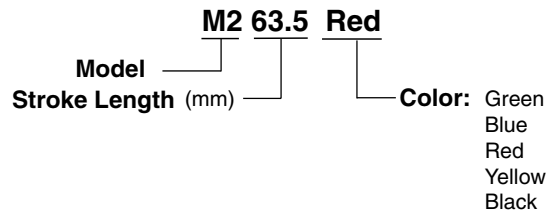

Model	Charging pressure (psi)	Color	Pounds Force (lbF)	
			Initial	
M2	650	Green	110	
M2	1300	Blue	225	
M2	1960	Red	340	
M2	2610	Yellow	450	
M2*	360-2610	Black	110-450	

* User specified charge pressure.

S Stroke	Pounds Force (lbF) at full stroke				L ± 0.25	L min	Gas vol. (l)	Weight (kg)
	M2 Green	M2 Blue	M2 Red	M2 Yellow				
7	173	344	517	689	56	49	0.005	0.13
10	173	344	517	689	62	52	0.005	0.14
12.7	173	344	517	690	67.4	54.7	0.006	0.15
15	173	346	519	690	72	57	0.007	0.16
16	173	346	519	690	74	58	0.007	0.16
25	173	346	519	692	92	67	0.010	0.18
38.1	173	346	522	695	118.2	80.1	0.015	0.20
50	173	346	522	695	142	92	0.019	0.22
63.5	17	342	510	679	172	108.5	0.024	0.26
80	171	342	513	683	205	125	0.029	0.30
100	171	342	515	686	245	145	0.036	0.33
125	171	344	515	689	295	170	0.044	0.39

BASIC INFORMATION

Pressure medium Nitrogen
 Max. charging pressure 180 bar/2610 psi
 Min. charging pressure 25 bar/360 psi
 Operating temperature 0 - 80°C/0 - 176°F
 Force increase by temperature ±0.3%/°C
 Recommended max strokes/min ~ 80-100
 Max piston rod velocity 1.6 m/s
 Tube Black oxide
 Repair kit M2

MOUNTING POSSIBILITIES

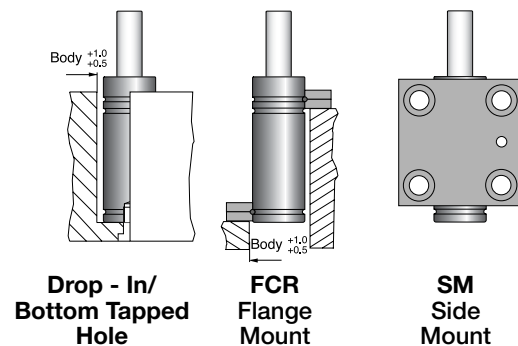

We reserve the right to add, delete or modify components without notification.

All dimensions are stated in mm. All dimensions are nominal unless tolerance is stated.

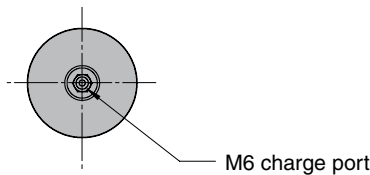
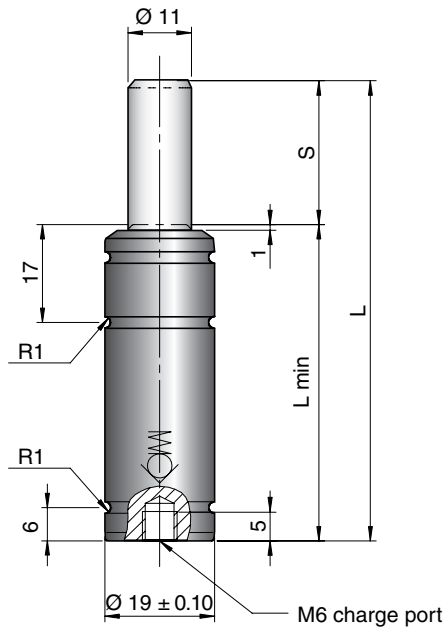

The Powerline series is our shortest and most powerful piston rod sealed gas spring, giving you a great deal of force in a very small amount of space.

The X springs are available with stroke lengths between 7 and 125 mm.

The X 170 has a bottom port for gas charging that can also be used to connect to a Micro Hose™ hose system.

The X 170 has an upper ISO-Standard C-groove and a lower C-groove which together with a threaded bottom hole offer various mounting possibilities.

Millimeters to Inches: mm ÷ 25.4 = inches
Kilograms to Pounds: Kg ÷ 0.45 = pounds
Pounds Force to DecaNewtons: LbF x 0.4448 = decaNewtons

Order No.	S Stroke	Pounds Force (lbF) at 2610 psi		L ± 0.25	L min
		Initial	End force*		
X 170-007	7	382	630	44	37
X 170-010	10			50	40
X 170-015	15			60	45
X 170-019	19			68	49
X 170-025	25			80	55
X 170-038	38			106	68
X 170-050	50			130	80
X 170-063	63			156	93
X 170-075	75			185	110
X 170-080	80			195	115
X 170-100	100			235	135
X 170-125	125			285	160

* = at full stroke

BASIC INFORMATION

- Pressure medium Nitrogen
- Max. charging pressure 180 bar/2610 psi
- Min. charging pressure 25 bar/360 psi
- Operating temperature 0 - 80°C/0 - 176°F
- Force increase by temperature ±0.3%/°C
- Recommended max strokes/min ~ 40-100 (at 20°C)
- Max piston rod velocity..... 1.6 m/s
- Rod surface Nitrided
- Tube surface Black oxide
- Not repairable

MOUNTING POSSIBILITIES

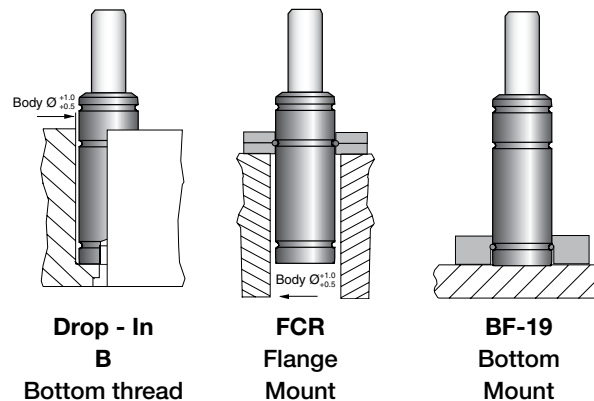

A business of BARNES GROUP INC

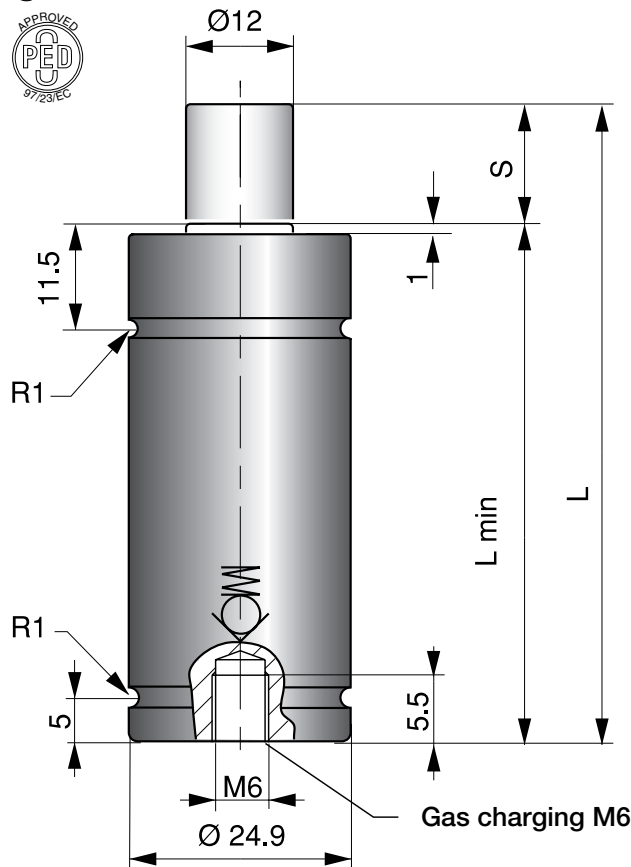

As with all of the CU springs, the CU 420 has a very high force compared to its outer diameter.

The max. recommended frequency for the spring is 100 strokes/minute. The M6 thread in the base of the spring is used for filling and is also a mounting option.

Millimeters to Inches: $mm \div 25.4 = \text{inches}$
 Kilograms to Pounds: $Kg \div 0.45 = \text{pounds}$
 Pounds Force to DecaNewtons:
 $LbF \times 0.4448 = \text{decaNewtons}$

Order No.	S Stroke	Pounds Force (lbF) at 2175 psi		L ± 0.25	L min	Gas vol. (l)	Weight (kg)
		Initial	End force*				
CU 420-006	6	950	1575	56	50	0.003	0.13
CU 420-010	10		1550	70	60	0.005	0.15
CU 420-016	16		1550	91	75	0.008	0.18
CU 420-025	25		1550	120	95	0.011	0.22
CU 420-032	32		1700	140	108	0.021	0.24
CU 420-040	40		1700	165	125	0.026	0.27
CU 420-050	50		1700	195	145	0.032	0.31

* = at full stroke

BASIC INFORMATION

Pressure medium.....Nitrogen
 Max. charging pressure 150 bar/2175 psi
 Min. charging pressure 25 bar/360 psi
 Operating temperature 0 - 80°C/0 - 176°F
 Force increase by temperature..... $\pm 0.3\%/^{\circ}C$
 Recommended max strokes/min..... ~100
 Max piston rod velocity..... 0.5 m/s
 Rod surface Black Nitride
 Tube surface Black Nitride
 Not repairable

MOUNTING POSSIBILITIES

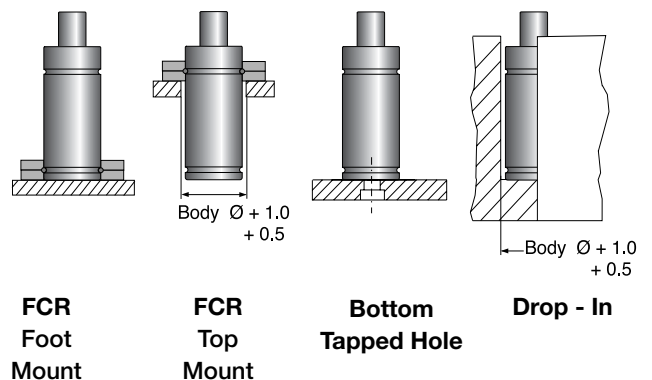

We reserve the right to add, delete or modify components without notification.
 All dimensions are stated in mm.
 All dimensions are nominal unless tolerance is stated.

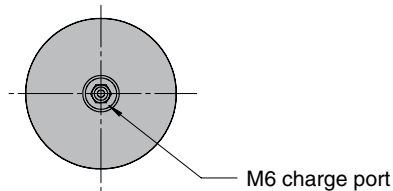
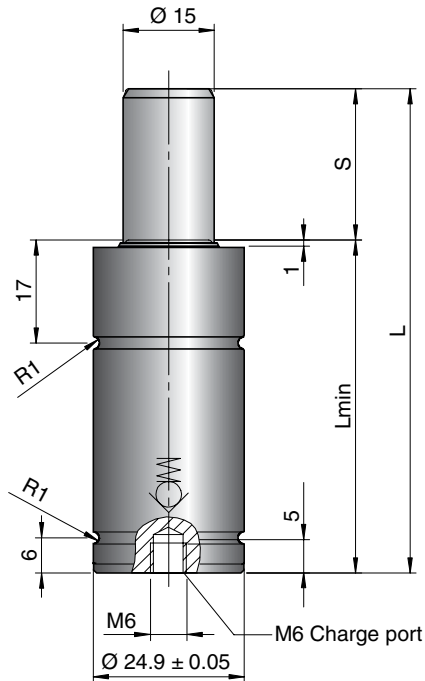

The Powerline Series is our shortest and most powerful piston rod sealed gas spring, giving you a great deal of force in a very small amount of space.

The Powerline springs are available with stroke lengths between 7 and 125 mm.

The X 320 has a bottom port for gas charging that can also be used to connect to a Micro Hose™ hose system.

The X 320 has an upper ISO-Standard C-groove that together with a threaded bottom hole offer various mounting possibilities using our standard mounts.

Millimeters to Inches: mm ÷ 25.4 = inches

Kilograms to Pounds: Kg ÷ 0.45 = pounds

**Pounds Force to DecaNewtons:
LbF x 0.4448 = decaNewtons**

Order No.	S Stroke	Pounds Force (lbF) at 2610 psi		L ± 0.25	L min
		Initial	End force*		
X 320-007	7	720	1080	44	37
X 320-010	10		1100	50	40
X 320-015	15		1150	60	45
X 320-019	19		1150	68	49
X 320-025	25		1170	80	55
X 320-038	38		1190	106	68
X 320-050	50		1190	130	80
X 320-063	63		1190	156	93
X 320-075	75		1190	185	110
X 320-080	80		1190	195	115
X 320-100	100		1190	235	135
X 320-125	125		1190	285	160

* = at full stroke

BASIC INFORMATION

Pressure medium Nitrogen
 Max. charging pressure 180 bar/2610 psi
 Min. charging pressure 25 bar/360 psi
 Operating temperature 0 - 80°C/0 - 176°F
 Force increase by temperature ±0.3%/°C
 Recommended max strokes/min ~ 40-100 (at 20°C)
 Max piston rod velocity 1.6 m/s
 Rod surface Nitrided
 Tube surface Black oxide
 Not repairable

MOUNTING POSSIBILITIES

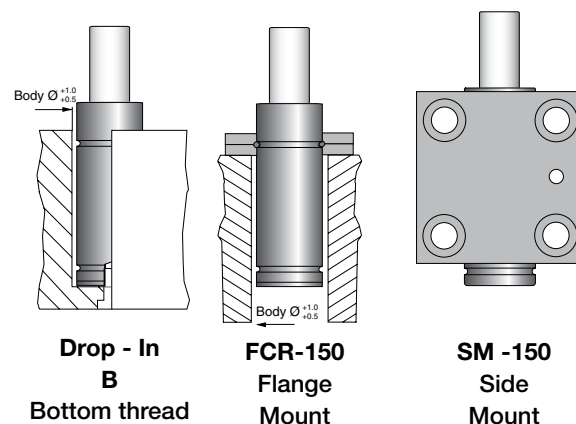

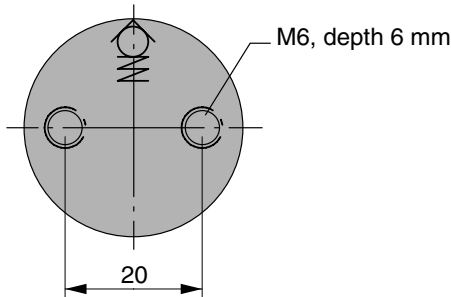
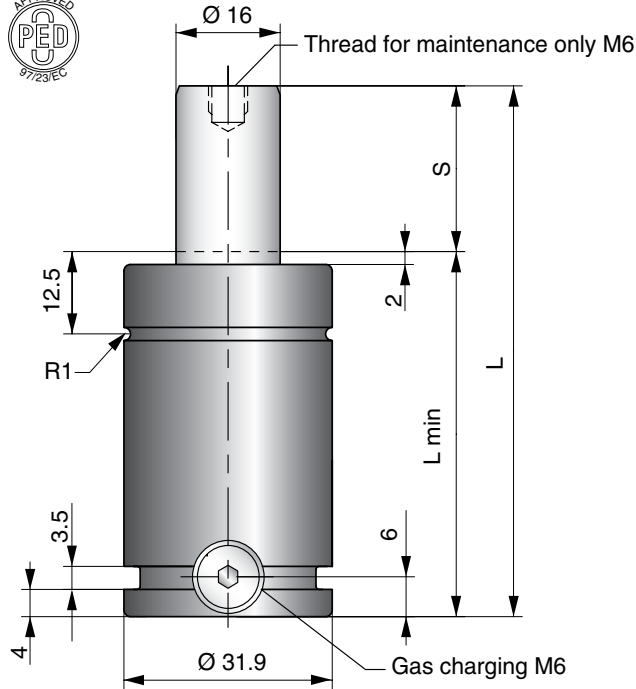

The Powerline gas springs are our shortest, with more power to give you a great deal of force in a very small amount of space.

There is a side port for gas filling that can also be used to connect a hose system.

An upper C-groove, lower U-groove together with two M6 threaded holes allow various mounting possibilities using our standard mounts.

Millimeters to Inches: mm ÷ 25.4 = inches
Kilograms to Pounds: Kg ÷ 0.45 = pounds
Pounds Force to DecaNewtons: LbF x 0.4448 = decaNewtons

Order No.	S Stroke	Pounds Force (lbF) at 2610 psi		L ± 0.25	L min
		Initial	End force*		
X 350-010	10		1330	50	40
X 350-013	13		1190	56	43
X 350-016	16		1210	62	46
X 350-019	19		1260	68	49
X 350-025	25		1260	80	55
X 350-032	32		1260	94	62
X 350-038	38	810	1240	106	68
X 350-050	50		1260	130	80
X 350-063	63		1260	156	93
X 350-075	75		1260	180	105
X 350-080	80		1240	190	110
X 350-100	100		1240	230	130
X 350-125	125		1240	280	155

* = at full stroke

BASIC INFORMATION

Pressure medium Nitrogen
 Max. charging pressure 180 bar/2610 psi
 Min. charging pressure 25 bar/360 psi
 Operating temperature 0 - 80°C/0 - 170°F
 Force increase by temperature ±0.3%/°C
 Recommended max strokes/min ~ 50-100
 Max piston rod velocity 1.6 m/s
 Tube Black oxide
 Repair kit X 350

MOUNTING POSSIBILITIES

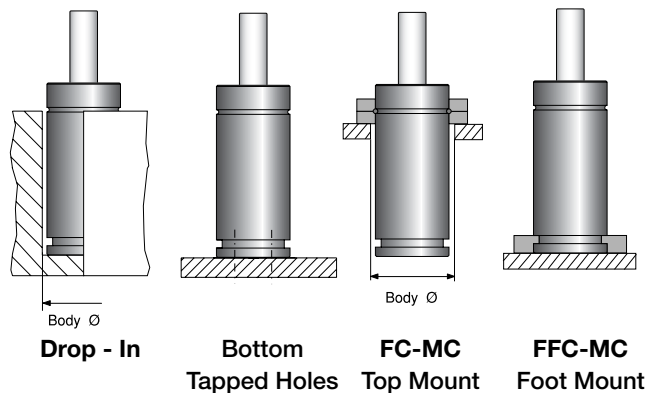

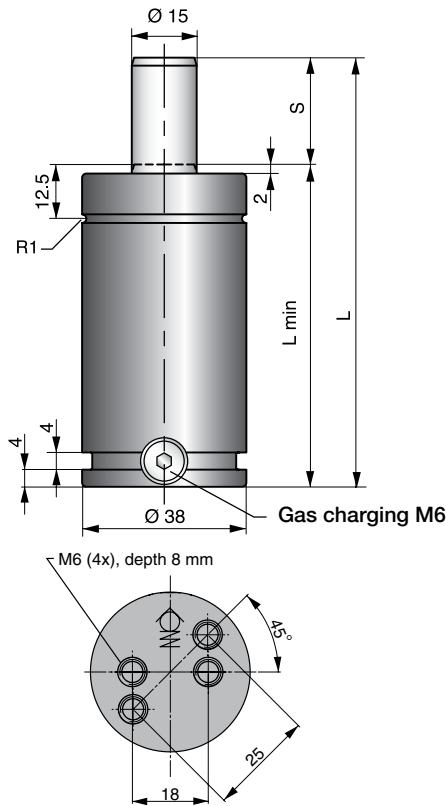

The basic line of gas springs is the TU line. Sizes 250 to 7500 correspond to the ISO 11901 standard for gas springs.

The total length is 50 mm + (2 x stroke).

Millimeters to Inches: mm ÷ 25.4 = inches
Kilograms to Pounds: Kg ÷ 0.45 = pounds
Pounds Force to DecaNewtons:
 LbF x 0.4448 = decaNewtons

Order No.	S Stroke	Pounds Force (lbF) at 2175 psi		L ± 0.25	L min	Gas vol. (l)	Weight (kg)	
		Initial	End force*					
TU 250-010	10	600	790	70	60	0.011	0.43	✓
TU 250-012	12.7		790	75.4	62.7	0.013	0.44	
TU 250-016	16		790	82	66	0.016	0.46	✓
TU 250-019	19		790	88	69	0.019	0.48	✓
TU 250-025	25		790	100	75	0.023	0.50	✓
TU 250-038	38.1		790	126.2	86.1	0.032	0.54	
TU 250-050	50		790	150	100	0.041	0.58	✓
TU 250-063	63.5		790	177	113.5	0.051	0.67	
TU 250-080	80		790	210	130	0.062	0.72	✓
TU 250-100	100		790	250	150	0.077	0.83	
TU 250-125	125	790	300	175	0.089	0.98		

* = at full stroke

BASIC INFORMATION

Pressure medium Nitrogen
 Max. charging pressure 150 bar/2175 psi
 Min. charging pressure 50 bar/725 psi
 Operating temperature 0 - 80°C/0 - 176°F
 Force increase by temperature ±0.3%/°C
 Recommended max strokes/min ~ 80-100
 Max piston rod velocity 1.6 m/s
 Tube Black oxide
 Repair kit TU 250

MOUNTING POSSIBILITIES

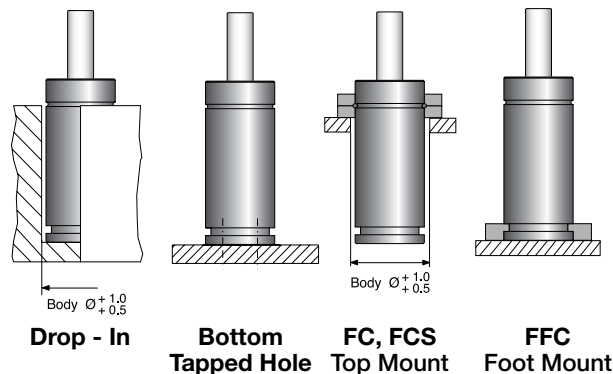

A business of BARNES GROUP INC

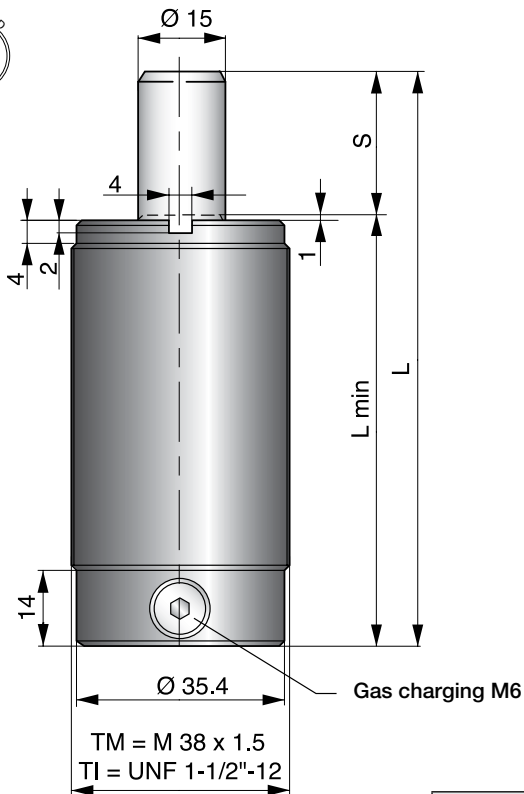

The TM and TI are threaded body 250 springs with the same length as the TU 250.

The TM spring has a metric thread M38 x 1.5.

The TI spring has an inch thread 1½-12 UNF.

Millimeters to Inches: mm ÷ 25.4 = inches
Kilograms to Pounds: Kg ÷ 0.45 = pounds
Pounds Force to DecaNewtons: LbF x 0.4448 = decaNewtons

Order No.	S Stroke	Pounds Force (lbF) at 2175 psi		L ± 0.25	L min	Gas vol. (l)	Weight (kg)
		Initial	End force*				
TM/TI 250-012	12.7	600	765	75.4	62.7	0.015	0.37
TM/TI 250-025	25		765	100	75	0.024	0.42
TM/TI 250-038	38.1		765	126.2	88.1	0.033	0.47
TM/TI 250-050	50		765	150	100	0.042	0.52
TM/TI 250-063	63.5		790	177	113.5	0.052	0.57
TM/TI 250-080	80		790	210	130	0.063	0.64
TM/TI 250-100	100		790	250	150	0.078	0.72
TM/TI 250-125	125		790	300	175	TC	TC

* = at full stroke

BASIC INFORMATION

Pressure mediumNitrogen
 Max. charging pressure 150 bar/2175 psi
 Min. charging pressure 50 bar/725 psi
 Operating temperature 0 - 80°C/0 - 176°F
 Force increase by temperature ±0.3%/°C
 Recommended max strokes/min~ 80-100
 Max piston rod velocity.....1.6 m/s
 TubeBlack oxide
 Repair kit TU 250

MOUNTING POSSIBILITIES

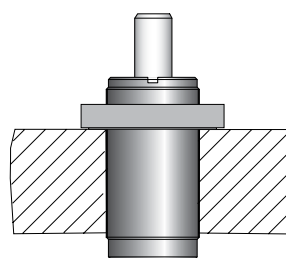

**FRM, FRI,
FHM, FHI**
Lock nut

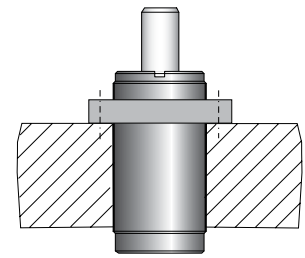

FTM, FTI
Flange mount

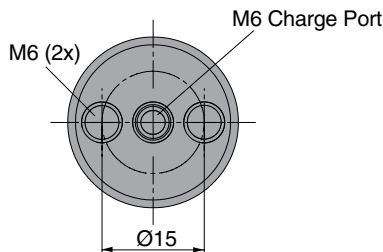
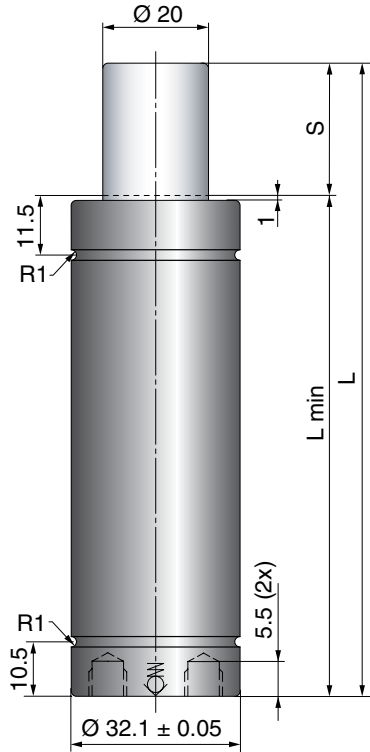

The CU gas spring is a very compact bore sealed gas spring that gives a high force in a limited space. Springs with stroke lengths over 25 mm should always be attached to the tool, using a flange or the tapped holes in the bottom of the spring. We also recommend shorter stroke springs be fastened for optimal service life.

Millimeters to Inches: $mm \div 25.4 = \text{inches}$
 Kilograms to Pounds: $Kg \div 0.45 = \text{pounds}$
 Pounds Force to DecaNewtons:
 $LbF \times 0.4448 = \text{decaNewtons}$

Order No.	S Stroke	Pounds Force (lbF) at 2175 psi		L ± 0.25	L min	Gas vol. (l)	Weight (kg)
		Initial	End force**				
CU 740-006	6	1660	2200	63	57	0.012	0.20
CU 740-010	10		2250	75	65	0.017	0.24
CU 740-016	16		2475	93	77	0.024	0.28
CU 740-025	25		2700	120	95	0.034	0.33
CU 740-032	32*		2700	140	108	0.042	0.37
CU 740-040	40*		2700	165	125	0.052	0.42
CU 740-050	50*		2700	195	145	0.063	0.48

* = Should always be attached to the tool using the tapped holes in the bottom or a flange
 ** = at full stroke

BASIC INFORMATION

Pressure medium Nitrogen
 Max. charging pressure 150 bar/2175 psi
 Min. charging pressure 25 bar/360 psi
 Operating temperature 0 - 80°C/0 - 176°F
 Force increase by temperature ±0.3%/°C
 Recommended max strokes/min ~ 50-100 (at 20°C)
 Max piston rod velocity..... 0.5 m/s
 Rod surface Nitrided
 Tube surface Nitrided
 Not repairable

MOUNTING POSSIBILITIES

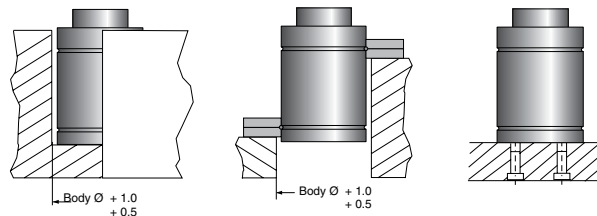

Drop - In

FC-MC
Top
Mount

B
Bottom
thread

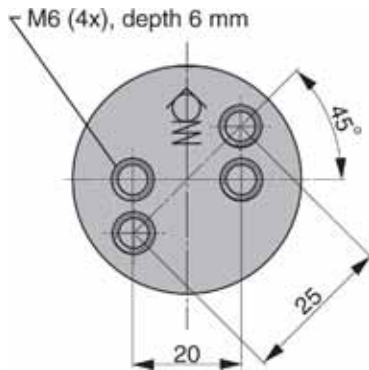
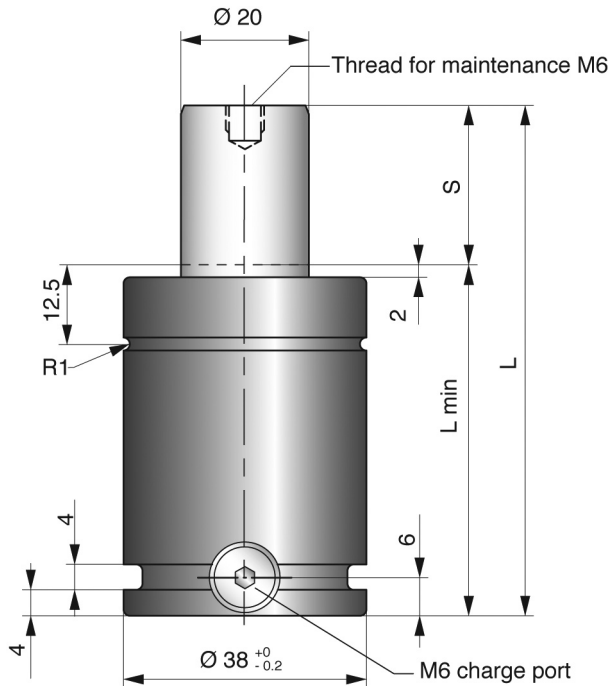

The Powerline gas springs are a new series.

These gas springs are our shortest, with more power to give you a great deal of force in a very small amount of space.

There is a side port for gas filling that can also be used to connect a hose system.

An upper C-groove, lower U-groove together with two M6 threaded holes allow various mounting possibilities using our standard mounts.

Millimeters to Inches: mm ÷ 25.4 = inches
Kilograms to Pounds: Kg ÷ 0.45 = pounds
Pounds Force to DecaNewtons: LbF x 0.4448 = decaNewtons

Order No.	S Stroke	Pounds Force (lbF) at 2175 psi		L ± 0.25	L min
		Initial	End force*		
X 500-010	10	1060	1620	50	40
X 500-013	13		1600	56	43
X 500-016	16		1620	62	46
X 500-019	19		1660	68	49
X 500-025	25		1640	80	55
X 500-032	32		1620	94	62
X 500-038	38		1620	106	68
X 500-050	50		1620	130	80
X 500-063	63		1620	156	93
X 500-075	75		1600	180	105
X 500-080	80		1600	190	110
X 500-100	100		1600	230	130
X 500-125	125		1600	280	155

* = at full stroke

BASIC INFORMATION

Pressure mediumNitrogen
 Max. charging pressure 150 bar/2175 psi
 Min. charging pressure 25 bar/360 psi
 Operating temperature 0 - 80°C/0 - 170°F
 Force increase by temperature ±0.3%/°C
 Recommended max strokes/min~ 50-100
 Max piston rod velocity.....1.6 m/s
 TubeBlack oxide
 Repair kit X 500

MOUNTING POSSIBILITIES

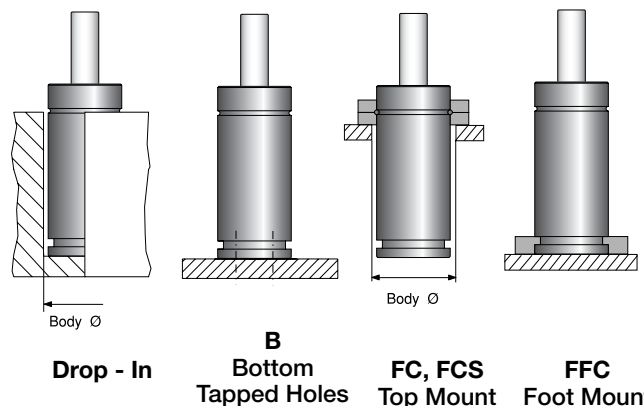

We reserve the right to add, delete or modify components without notification.
 All dimensions are stated in mm.
 All dimensions are nominal unless tolerance is stated.

A business of BARNES GROUP INC

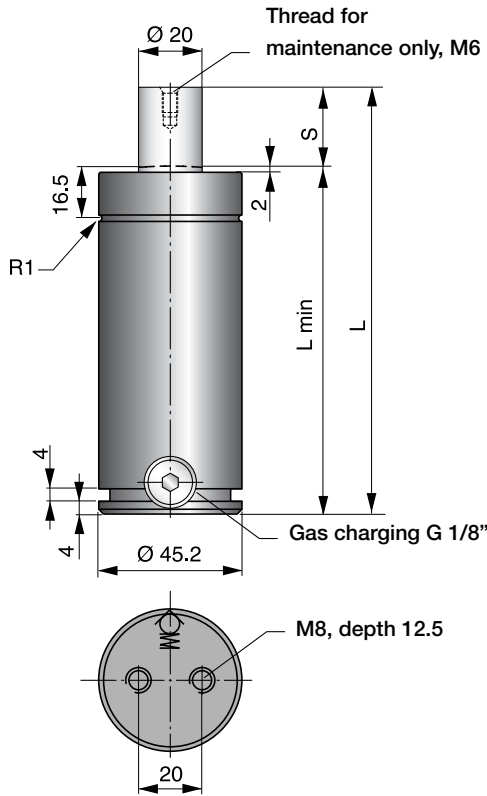

The basic line of gas springs is the TU- line. Sizes 250 to 7500 correspond to the ISO 11901 standard for gas springs.

The TU 500 has a total length of 85 mm + (2 x stroke).

The thread in the piston rod top is to be used for maintenance only.

Millimeters to Inches: mm ÷ 25.4 = inches
Kilograms to Pounds: Kg ÷ 0.45 = pounds
Pounds Force to DecaNewtons: LbF x 0.4448 = decaNewtons

Order No.	S Stroke	Pounds Force (lbF) at 2175 psi		L ± 0.25	L min	Gas vol. (l)	Weight (kg)	ISO
		Initial	End force*					
TU 500-010	10	1055	1350	105	95	0.023	0.96	
TU 500-012	12.7		1370	110.4	97.7	0.025	1.04	
TU 500-025	25		1440	135	110	0.038	1.13	✓
TU 500-038	38.1		1460	161.2	123.1	0.051	1.22	
TU 500-050	50		1480	185	135	0.063	1.30	✓
TU 500-063	63.5		1480	212	148.5	0.077	1.41	
TU 500-080	80		1510	245	165	0.093	1.55	✓
TU 500-100	100		1510	285	185	0.114	1.72	

* = at full stroke

BASIC INFORMATION

Pressure medium Nitrogen
 Max. charging pressure 150 bar/2175 psi
 Min. charging pressure 25 bar/360 psi
 Operating temperature 0 - 80°C/0 - 176°F
 Force increase by temperature ±0.3%/°C
 Recommended max strokes/min ~ 40-80
 Max piston rod velocity 1.6 m/s
 Tube Black oxide
 Repair kit TU 500

MOUNTING POSSIBILITIES

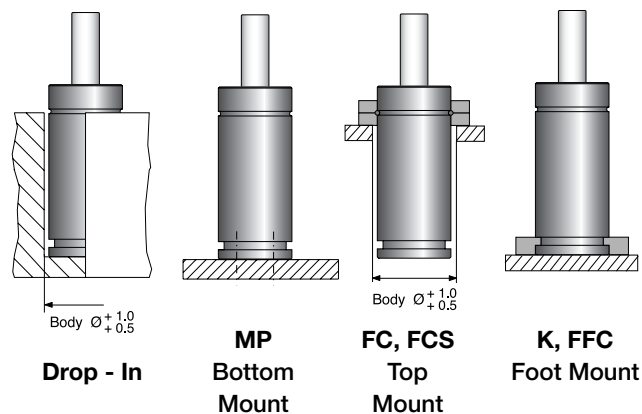

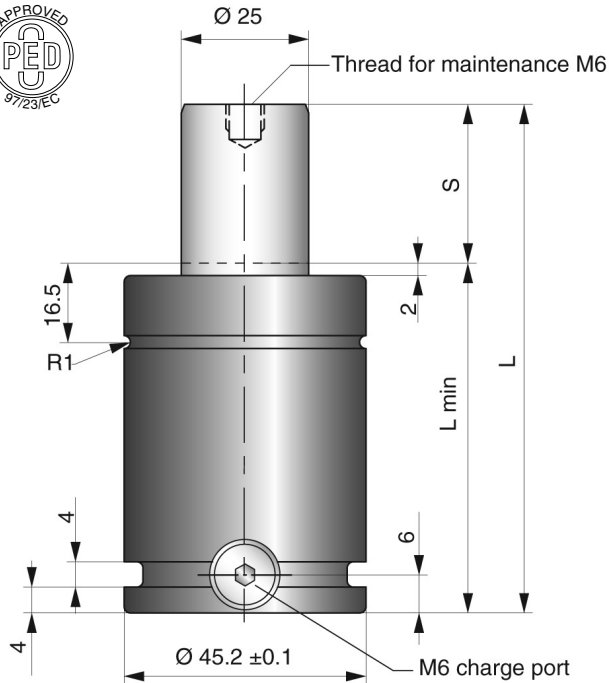

The Powerline gas springs are our shortest, with more power to give you a great deal of force in a very small amount of space.

There is a side port for gas filling that can also be used to connect a hose system.

An upper C-groove, lower U-groove together with two M8 threaded holes allow various mounting possibilities using our standard mounts.

Millimeters to Inches: $mm \div 25.4 = \text{inches}$
 Kilograms to Pounds: $Kg \div 0.45 = \text{pounds}$
 Pounds Force to DecaNewtons:
 $LbF \times 0.4448 = \text{decaNewtons}$

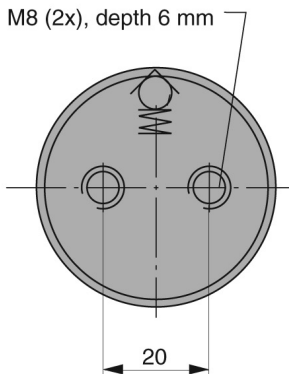

Order No.	S Stroke	Pounds Force (lbF) at 2175 psi		L ± 0.25	L min	Gas vol. (l)	Weight (kg)
		Initial	End force*				
X 750-010	10	1665	2720	52	42	0.02	0.37
X 750-013	13		2720	58	45	0.02	0.39
X 750-016	16		2720	64	48	0.03	0.41
X 750-019	1		2630	70	51	0.03	0.41
X 750-025	25		2650	82	57	0.04	0.45
X 750-032	32		2650	96	64	0.05	0.50
X 750-038	38		2650	108	70	0.05	0.53
X 750-050	50		2650	132	82	0.07	0.61
X 750-063	63		2650	158	95	0.09	0.69
X 750-075	75		2675	182	107	0.10	0.77
X 750-080	80		2675	192	112	0.11	0.80
X 750-100	100		2675	232	132	0.13	0.93
X 750-125	125	2675	282	157	0.17	1.09	

* = at full stroke

BASIC INFORMATION

Pressure medium Nitrogen
 Max. charging pressure 150 bar/2175 psi
 Min. charging pressure 25 bar/360 psi
 Operating temperature 0 - 80°C/32 - 176°F
 Force increase by temperature ±0.3%/°C
 Recommended max strokes/min ~ 50-100
 Max piston rod velocity 1.6 m/s
 Rod surface Nitrided
 Tube surface Black oxide
 Repair kit X 750

MOUNTING POSSIBILITIES

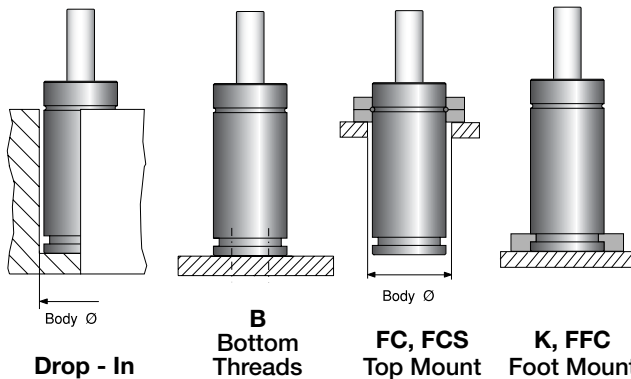

We reserve the right to add, delete or modify components without notification.
 All dimensions are stated in mm.
 All dimensions are nominal unless tolerance is stated.

A business of BARNES GROUP INC

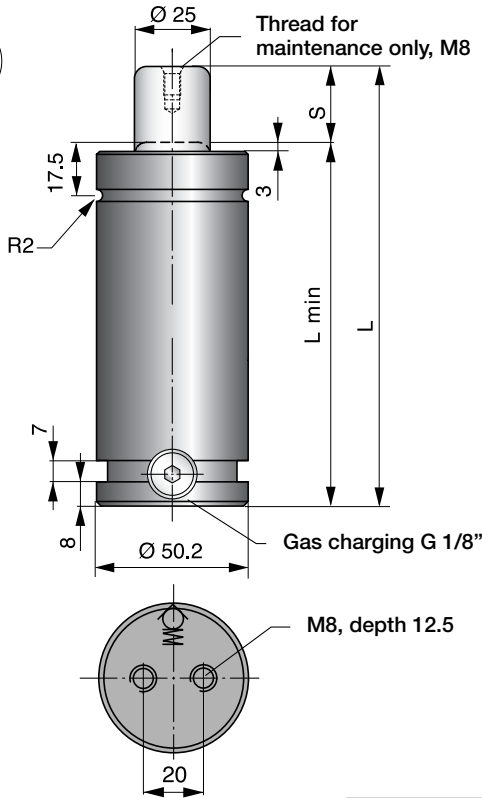

The basic line of gas springs is the TU line. Sizes 250 to 7500 correspond to the ISO 11 901 standard for gas springs.

Millimeters to Inches: mm ÷ 25.4 = inches
Kilograms to Pounds: Kg ÷ 0.45 = pounds
Pounds Force to DecaNewtons: LbF x 0.4448 = decaNewtons

Order No.	S Stroke	Pounds Force (lbF) at 2175 psi		L ± 0.25	L min	Gas vol. (l)	Weight (kg)	ISO
		Initial	End force*					
TU 750-012	12.7		2700	120.4	107.7	0.03	1.30	
TU 750-025	25		2700	145	120	0.04	1.45	✓
TU 750-038	38.1		2700	171.2	133.1	0.06	1.50	
TU 750-050	50		2700	195	145	0.07	1.70	✓
TU 750-063	63.5		2700	222	158.5	0.09	1.75	
TU 750-075	75		2700	245	170	0.10	1.85	
TU 750-080	80	1665	2700	255	175	0.11	1.95	✓
TU 750-100	100		2700	295	195	0.14	2.15	✓
TU 750-125	125		2720	345	220	0.17	2.40	✓
TU 750-160	160		2720	415	255	0.21	2.70	✓
TU 750-200	200		2720	495	295	0.26	3.10	
TU 750-250	250		2720	595	345	0.33	3.60	
TU 750-300	300		2720	695	395	0.39	4.10	

* = at full stroke

BASIC INFORMATION

Pressure medium Nitrogen
 Max. charging pressure 150 bar/2175 psi
 Min. charging pressure 25 bar/360 psi
 Operating temperature 0 - 80°C/0 - 176°F
 Force increase by temperature ±0.3%/°C
 Max piston rod velocity 1.6 m/s
 Tube Black oxide
 Repair kit TU 750

MOUNTING POSSIBILITIES

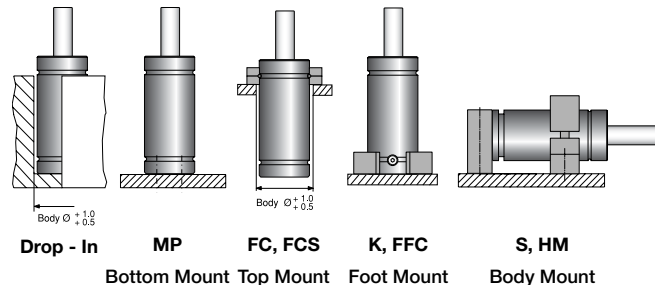

A business of BARNES GROUP INC

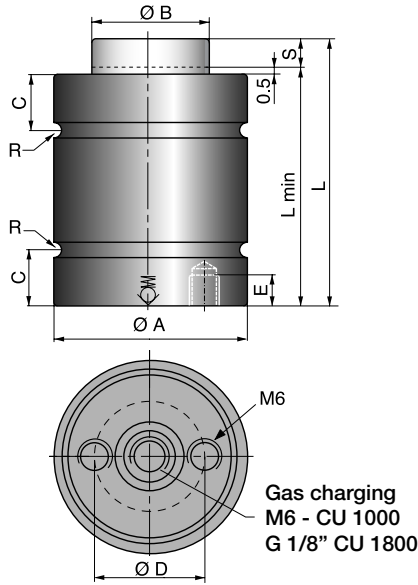

The CU gas spring is a very compact bore sealed gas spring, that gives a high force in a limited space. The max. frequency for the spring is 100 strokes/minute.

Springs with stroke lengths over 25 mm should always be attached to the tool, using a flange or the tapped holes in the bottom of the spring. We also recommend shorter stroke springs to be fastened for optimal service-life.

As an option, the CU springs can be delivered with a side-port plate for applications where a side port is needed, i.e. for use in hose systems.

Millimeters to Inches: mm ÷ 25.4 = inches
Kilograms to Pounds: Kg ÷ 0.45 = pounds
Pounds Force to DecaNewtons: LbF x 0.4448 = decaNewtons

Order No.	S Stroke	Pounds Force (lbF) at 2175 psi		L ± 0.25	L min	Ø A ± 0.1	Ø B	C	Ø D	E	R	Gas vol. (l)	Weight (kg)
		Initial	End force**										
CU 1000-006	6			61	55							0.014	0.3
CU 1000-010	10			78	68							0.024	0.4
CU 1000-016	16			100	84							0.036	0.5
CU 1000-025	25	2380	3595	135	110	37.9	20	10.5	17	6.5	1	0.056	0.6
CU 1000-032	32*			167	135							0.074	0.7
CU 1000-040	40*			195	155							0.092	0.8
CU 1000-050	50*			230	180							0.110	0.9
CU 1800-006	6		5620	66	60							0.030	0.6
CU 1800-010	10		5845	80	70							0.044	0.7
CU 1800-016	16		5845	106	90							0.072	0.8
CU 1800-025	25	4045	6070	135	110	50.2	30	14.5	26	6.5	2	0.100	1.0
CU 1800-032	32*		6070	162	130							0.126	1.2
CU 1800-040	40*		6295	190	150							0.150	1.4
CU 1800-050	50*		6520	220	170							0.179	1.6

* = Should always be attached to the tool using the tapped holes in the bottom or a flange

** = at full stroke

BASIC INFORMATION

- Pressure medium..... Nitrogen
- Max. charging pressure 150 bar/2175 psi
- Min. charging pressure 25 bar/360 psi
- Operating temperature 0 - 80°C/0 - 176°F
- Force increase by temperature..... ±0.3%/°C
- Recommended max strokes/min..... ~100
- Max piston rod velocity..... 0.5 m/s
- Rod surface Black Nitride
- Tube surface Black Nitride
- Repair kit CU 1000
- Repair kit CU 1800

MOUNTING POSSIBILITIES

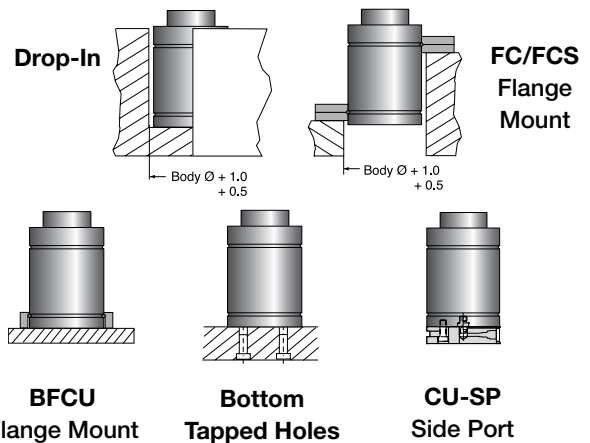

We reserve the right to add, delete or modify components without notification.
 All dimensions are stated in mm.
 All dimensions are nominal unless tolerance is stated.

X 1000 and XMS 1000

A business of BARNES GROUP INC

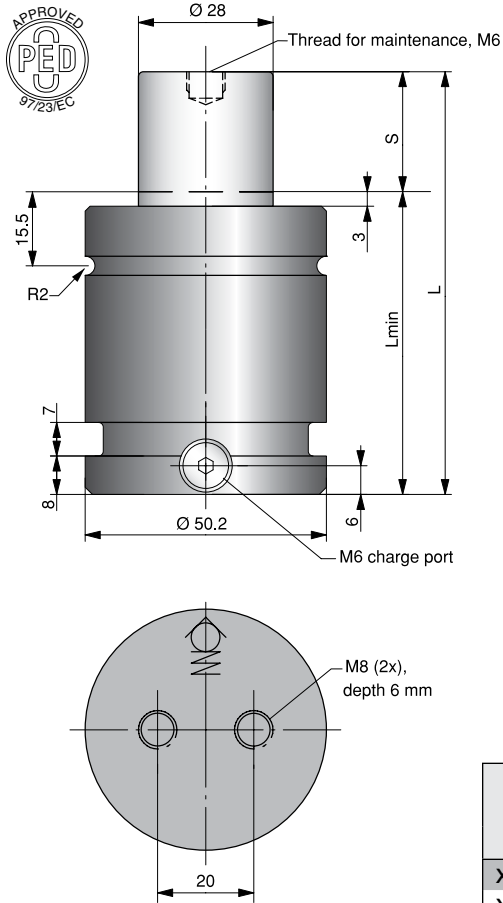

Powerline springs are piston rod sealed gas springs, our shortest and most powerful, giving you a great deal of force in a very small amount of space.

There is a side port for gas filling that can also be used to connect to a hose system.

An upper C-groove, lower U-groove together with two M8 threaded holes allow various mounting possibilities using our standard mounts.

Millimeters to Inches: mm ÷ 25.4 = inches

Kilograms to Pounds: Kg ÷ 0.45 = pounds

**Pounds Force to DecaNewtons:
LbF x 0.4448 = decaNewtons**

The X 1000 model is also available equipped with an M16 threaded tap for mounting. When ordering this version XMS 1000-xxx must be stated on the order.

Order No.	S Stroke	Pounds Force (lbF) at 2175 psi		L ± 0.25	L min	Gas vol. (l)	Weight (kg)
		Initial	End force*				
X/XMS 1000-013	13	2068	3103	64	51	0.03	0.52
X/XMS 1000-016	16		3103	70	54	0.04	0.54
X/XMS 1000-019	19		3147	76	57	0.04	0.56
X/XMS 1000-025	25		3192	88	63	0.05	0.61
X/XMS 1000-032	32		3215	102	70	0.06	0.66
X/XMS 1000-038	38		3260	114	76	0.07	0.71
X/XMS 1000-050	50		3282	138	88	0.09	0.81
X/XMS 1000-063	63		3305	164	101	0.11	0.91
X/XMS 1000-075	75		3305	188	113	0.13	1.02
X/XMS 1000-080	80		3327	198	118	0.14	1.05
X/XMS 1000-100	100		3327	238	138	0.17	1.20
X/XMS 1000-125	125		3327	288	163	0.21	1.40

* = at full stroke

BASIC INFORMATION

Pressure medium Nitrogen
 Max. charging pressure 150 bar/2175 psi
 Min. charging pressure 25 bar/360 psi
 Operating temperature 0 - 80°C/0 - 176°F
 Force increase by temperature ±0.3%/°C
 Recommended max strokes/min ~ 50-100
 Max piston rod velocity 1.6 m/s
 Tube Black oxide
 Repair kit X 1000

MOUNTING POSSIBILITIES

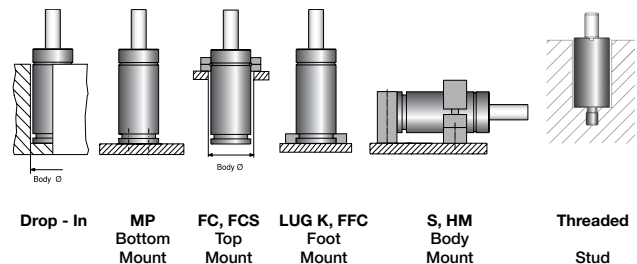

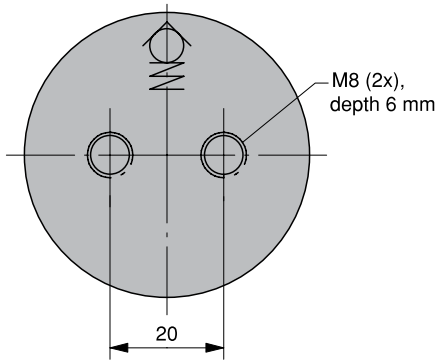
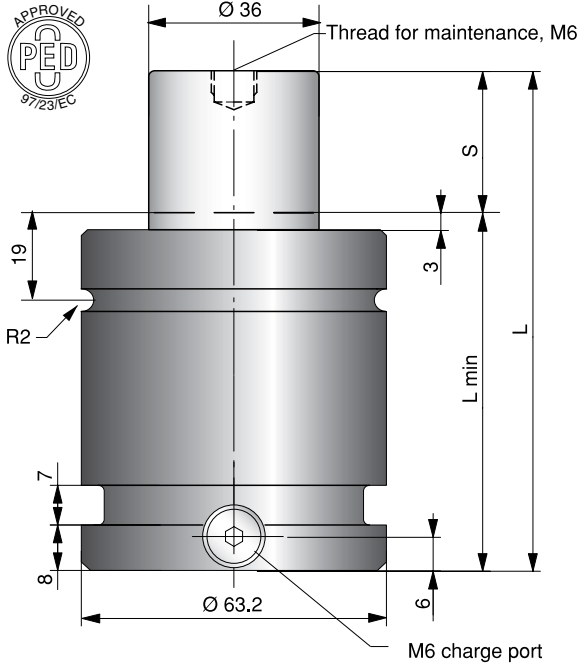

The Powerline gas springs are a new series.

These gas springs are our shortest, with more power to give you a great deal of force in a very small amount of space.

There is a side port for gas filling that can also be used to connect a hose system.

An upper C-groove, lower U-groove together with two M8 threaded holes allow various mounting possibilities using our standard mounts.

Millimeters to Inches: $mm \div 25.4 = \text{inches}$
 Kilograms to Pounds: $Kg \div 0.45 = \text{pounds}$
 Pounds Force to DecaNewtons:
 $LbF \times 0.4448 = \text{decaNewtons}$

Order No.	S Stroke	Pounds Force (lbF) at 2175 psi		L ± 0.25	L min	Gas vol. (l)	Weight (kg)
		Initial	End force*				
X 1500-013	13	3375	5395	70	57	0.05	0.9
X 1500-016	16		5420	76	60	0.06	0.9
X 1500-019	19		5440	82	63	0.07	1.0
X 1500-025	25		5365	94	69	0.08	1.0
X 1500-032	32		5355	108	76	0.11	1.1
X 1500-038	38		5375	120	82	0.12	1.2
X 1500-050	50		5395	144	94	0.15	1.3
X 1500-063	63		5420	170	107	0.19	1.4
X 1500-075	75		5440	194	119	0.22	1.4
X 1500-080	80		5440	204	124	0.24	1.4
X 1500-100	100		5465	244	144	0.29	1.9
X 1500-125	125		5465	294	169	0.36	2.2

* = at full stroke

BASIC INFORMATION

Pressure medium Nitrogen
 Max. charging pressure 150 bar/2175 psi
 Min. charging pressure 25 bar/360 psi
 Operating temperature 0 - 80°C/0 - 176°F
 Force increase by temperature $\pm 0.3\%/^{\circ}C$
 Recommended max strokes/min ~ 50-100
 Max piston rod velocity 1.6 m/s
 Tube Black oxide
 Repair kit X 1500

MOUNTING POSSIBILITIES

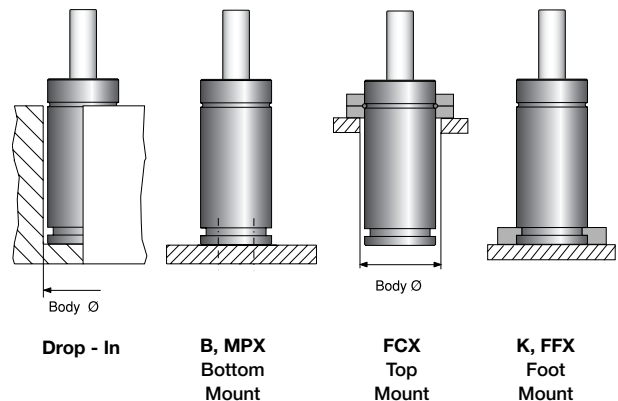

We reserve the right to add, delete or modify components without notification.
 All dimensions are stated in mm.
 All dimensions are nominal unless tolerance is stated.

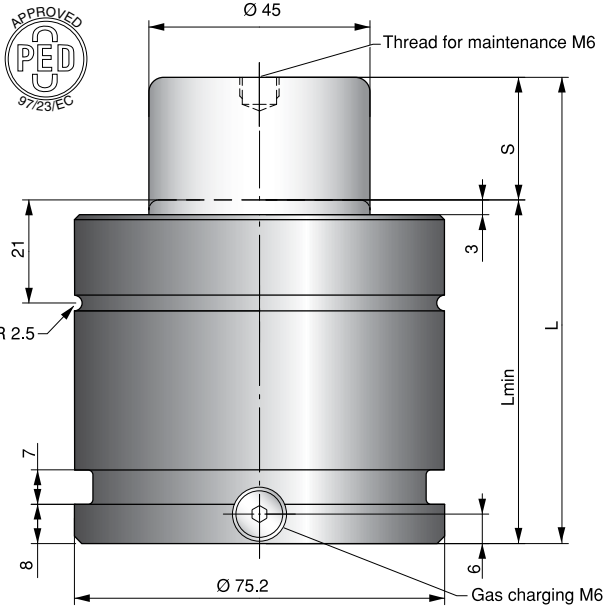

Powerline springs are Piston Rod Sealed that are our shortest and most powerful, giving you a great deal of force in a very small amount of space.

There is a side port for gas filling that can also be used to connect to a hose system.

An upper C-groove, lower U-groove together with four M8 threaded holes allow various mounting possibilities using our standard mounts.

Millimeters to Inches: mm ÷ 25.4 = inches
Kilograms to Pounds: Kg ÷ 0.45 = pounds
Pounds Force to DecaNewtons: LbF x 0.4448 = decaNewtons

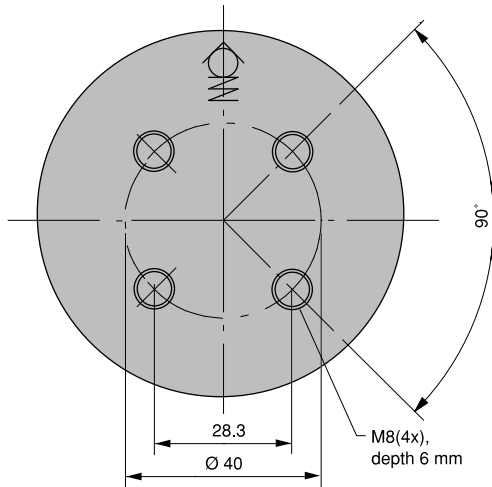

Order No.	S Stroke	Pounds Force (lbF) at 2175 psi		L ± 0.25	L min	Gas vol. (l)	Weight (kg)
		Initial	End force*				
X 2400-016	16		8611	77	61	0.09	1.4
X 2400-019	19		8656	83	64	0.10	1.44
X 2400-025	25		8701	95	70	0.13	1.54
X 2400-032	32		8678	109	77	0.16	1.63
X 2400-038	38		8633	121	83	0.18	1.71
X 2400-050	50	5396	8813	145	95	0.23	1.89
X 2400-063	63		8813	171	108	0.28	2.09
X 2400-075	75		8813	195	120	0.33	2.30
X 2400-080	80		8813	205	125	0.35	2.35
X 2400-100	100		8835	245	145	0.43	2.66
X 2400-125	125		8835	295	170	0.54	3.04

* = at full stroke

BASIC INFORMATION

Pressure medium Nitrogen
 Max. charging pressure 150 bar/2175 psi
 Min. charging pressure 25 bar/360 psi
 Operating temperature 0 - 80°C/0 - 176°F
 Force increase by temperature ±0.3%/°C
 Recommended max strokes/min ~ 50-100
 Max piston rod velocity 1.6 m/s
 Tube Black oxide
 Repair kit X 2400 (Note: Stroke length 16 not repairable.)

MOUNTING POSSIBILITIES

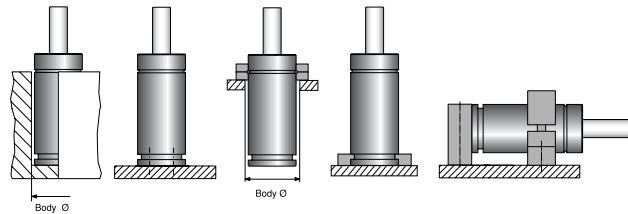

Drop - In MP Bottom Mount FC, FCS Top Mount LUG K, FFC Foot Mount S, HM Body Mount

A business of BARNES GROUP INC

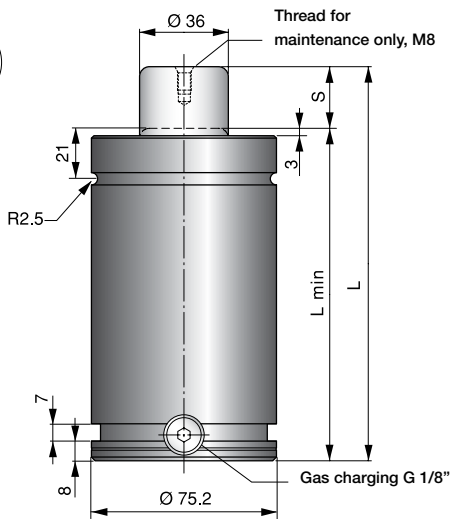

M8, depth 13 mm

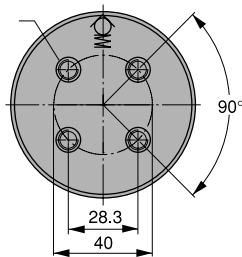

The basic line of gas springs is the TU line. Sizes 250 to 7500 correspond to the ISO 11901 standard for gas springs.

The thread in the piston rod top is to be used for maintenance only.

Millimeters to Inches: mm ÷ 25.4 = inches
Kilograms to Pounds: Kg ÷ 0.45 = pounds
Pounds Force to DecaNewtons: LbF x 0.4448 = decaNewtons

Order No.	S Stroke	Pounds Force (lbF) at 2175 psi		L ± 0.25	L min	Gas vol. (l)	Weight (kg)	ISO
		Initial	End force*					
TU 1500-025	25		5170	160	135	0.10	3.75	✓
TU 1500-038	38.1		5170	186.2	148.1	0.15	3.95	
TU 1500-050	50		5170	210	160	0.18	4.15	✓
TU 1500-063	63.5		5170	237	173.5	0.22	4.40	
TU 1500-075	75		5170	260	185	0.26	4.55	
TU 1500-080	80		5170	270	190	0.28	4.70	✓
TU 1500-100	100	3375	5170	310	210	0.34	5.10	✓
TU 1500-125	125		5170	360	235	0.42	5.55	✓
TU 1500-150	150		5170	410	260	0.50	6.10	
TU 1500-160	160		5170	430	270	0.53	6.25	✓
TU 1500-200	200		5170	510	310	0.68	6.90	
TU 1500-250	250		5170	610	360	0.81	7.80	
TU 1500-300	300		5170	710	410	0.96	8.90	

* = at full stroke

BASIC INFORMATION

Pressure medium Nitrogen
 Max. charging pressure 150 bar/2175 psi
 Min. charging pressure 25 bar/360 psi
 Operating temperature 0 - 80°C/0 - 176°F
 Force increase by temperature ±0.3%/°C
 Recommended max strokes/min ~ 15-40
 Max piston rod velocity 1.6 m/s
 Tube Black oxide
 Repair kit TU 1500

MOUNTING POSSIBILITIES

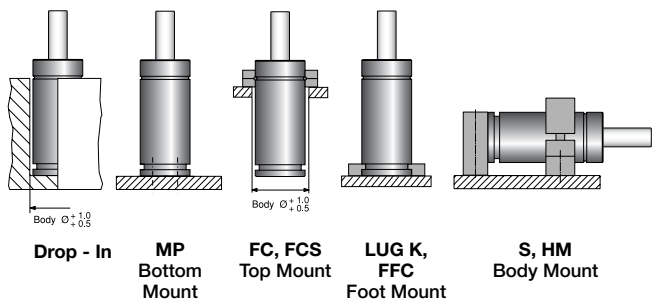

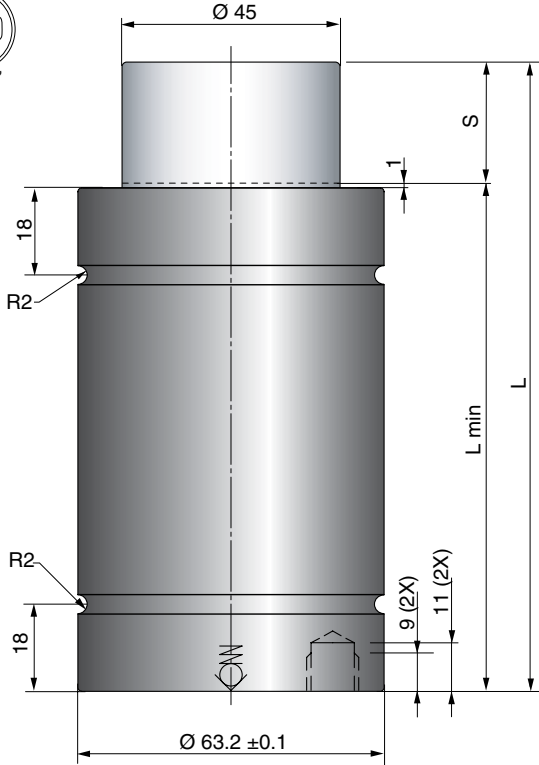

The CU gas spring is a very compact bore sealed gas spring, that gives a high force in a limited space.

Springs with stroke lengths over 25 mm should always be attached to the tool, using a flange or the tapped holes in the bottom of the spring. We also recommend shorter stroke springs to be fastened for optimal service-life.

As an option, this CU spring can be delivered with a side-port plate (SP) for applications where a side port is needed (i.e. for use in hose systems).

Millimeters to Inches: mm ÷ 25.4 = inches
Kilograms to Pounds: Kg ÷ 0.45 = pounds
Pounds Force to DecaNewtons: LbF x 0.4448 = decaNewtons

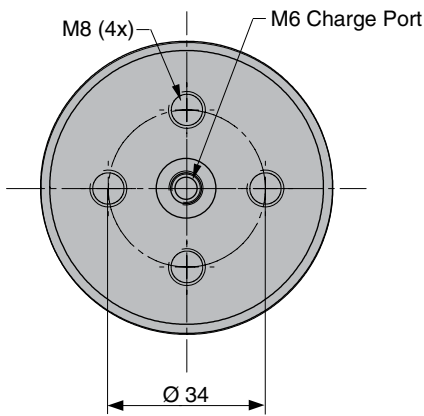

Order No.	S Stroke	Pounds Force (lbF) at 2175 psi		L ± 0.25	L min	Gas vol. (l)	Weight (kg)
		Initial	End force**				
CU 2900-010	10	6630	8655	85	75	0.08	1.1
CU 2900-016	16		9215	103	87	0.12	1.3
CU 2900-025	25		9665	130	105	0.16	1.5
CU 2900-032*	32*		9935	150	118	0.20	1.6
CU 2900-040*	40*		10160	175	135	0.24	1.8
CU 2900-050*	50*		10295	205	155	0.29	2.1

* = Should always be attached to the tool using the tapped holes in the bottom or a flange

** = at full stroke

BASIC INFORMATION

Pressure medium Nitrogen
 Max. charging pressure 150 bar/2175 psi
 Min. charging pressure 25 bar/360 psi
 Operating temperature 0 - 80°C/0 - 176°F
 Force increase by temperature ±0.3%/°C
 Recommended max strokes/min ~ 80-100 (at 20°C)
 Max piston rod velocity 0.5 m/s
 Rod surface Nitrided
 Tube surface Nitrided
 Repair kit CU 2900

MOUNTING POSSIBILITIES

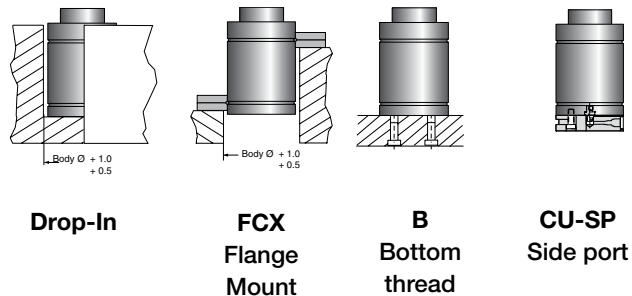

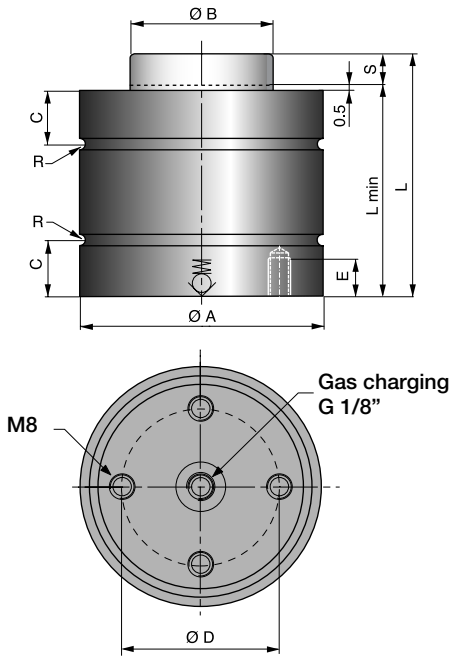

The CU gas spring is a very compact bore sealed gas spring, that gives a high force in a limited space. The max. frequency for the spring is 100 strokes/minute.

Springs with stroke lengths over 25 mm should always be attached to the tool, using a flange or the tapped holes in the bottom of the spring. We also recommend shorter stroke springs to be fastened for optimal service-life.

As an option, the CU springs can be delivered with a side-port plate for applications where a side port is needed, i.e. for use in hose systems.

Millimeters to Inches: $mm \div 25.4 = \text{inches}$
 Kilograms to Pounds: $Kg \div 0.45 = \text{pounds}$
 Pounds Force to DecaNewtons:
 $LbF \times 0.4448 = \text{decaNewtons}$

Order No.	S Stroke	Pounds Force (lbF) at 2175 psi		L ± 0.25	L min	Ø A ± 0.1	Ø B	C	Ø D	E	R	Gas vol. (l)	Weight (kg)
		Initial	End force**										
CU 4700-010	10	10570	15100	80	70	75.2	50	18	40	9	1.5	0.10	1.4
CU 4700-016	16		14800	106	90							0.17	1.7
CU 4700-025	25		15300	135	110							0.24	2.0
CU 4700-032	32*		15100	167	135							0.32	2.4
CU 4700-040	40*		15100	200	160							0.41	2.8
CU 4700-050	50*		15100	240	190							0.52	3.3

* = Should always be attached to the tool using the tapped holes in the bottom or a flange
 ** = at full stroke

BASIC INFORMATION

Pressure medium..... Nitrogen
 Max. charging pressure 150 bar/2175 psi
 Min. charging pressure 25 bar/360 psi
 Operating temperature 0 - 80°C/0 - 176°F
 Force increase by temperature..... ±0.3%/°C
 Recommended max strokes/min..... ~80-100
 Max piston rod velocity..... 0.5 m/s
 Rod surface Black Nitride
 Tube surface Black Nitride
 Repair kit CU 4700

MOUNTING POSSIBILITIES

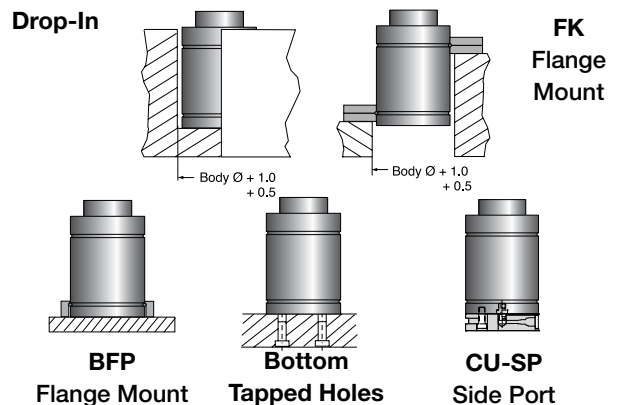

We reserve the right to add, delete or modify components without notification.
 All dimensions are stated in mm.
 All dimensions are nominal unless tolerance is stated.

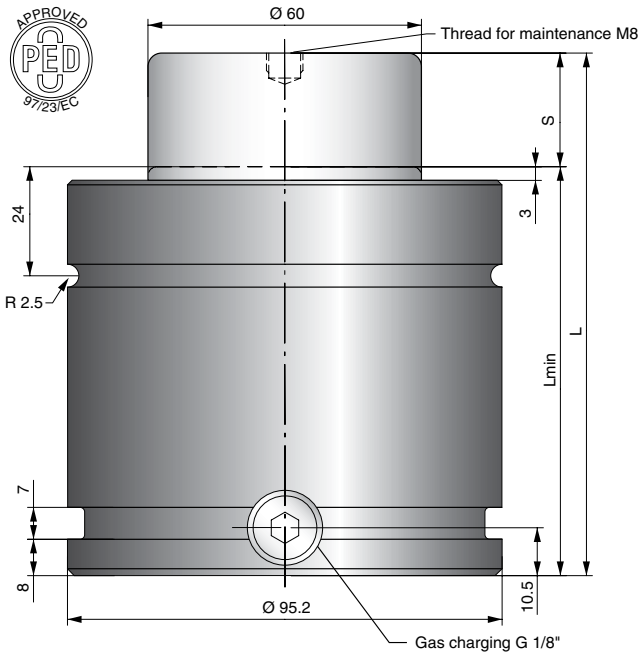

Powerline springs are piston rod sealed gas springs, our shortest and most powerful, giving you a great deal of force in a very small amount of space.

There is a side port for gas filling that can also be used to connect to a hose system.

An upper C-groove, lower U-groove together with four M8 threaded holes allow various mounting possibilities using our standard mounts.

Millimeters to Inches: mm ÷ 25.4 = inches

Kilograms to Pounds: Kg ÷ 0.45 = pounds

**Pounds Force to DecaNewtons:
LbF x 0.4448 = decaNewtons**

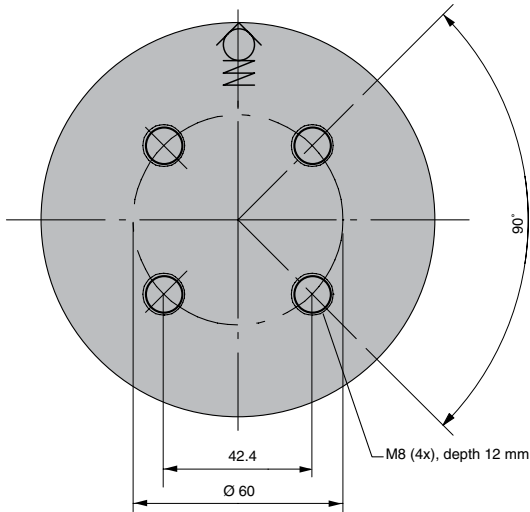

Order No.	S Stroke	Pounds Force (lbF) at 2175 psi		L ± 0.25	L min	Gas vol. (l)	Weight (kg)
		Initial	End force*				
X 4200-016	16	9440	13870	90	74	0.15	2.60
X 4200-019	19		14320	96	77	0.18	2.70
X 4200-025	25		13670	108	83	0.26	2.90
X 4200-032	32		14455	122	90	0.30	3.05
X 4200-038	38		14790	134	96	0.32	3.20
X 4200-050	50		15060	15	108	0.40	3.50
X 4200-063	63		15240	184	121	0.49	3.80
X 4200-075	75		15285	208	133	0.58	4.20
X 4200-080	80		15420	218	138	0.61	4.40
X 4200-100	100		15535	258	158	0.74	4.90
X 4200-125	125		15645	308	170	0.91	5.40

* = at full stroke

BASIC INFORMATION

Pressure medium Nitrogen
 Max. charging pressure 150 bar/2175 psi
 Min. charging pressure 25 bar/360 psi
 Operating temperature 0 - 80°C/0 - 176°F
 Force increase by temperature ±0.3%/°C
 Recommended max strokes/min ~ 30-100
 Max piston rod velocity 1.6 m/s
 Tube Black oxide
 Repair kit X 4200

MOUNTING POSSIBILITIES

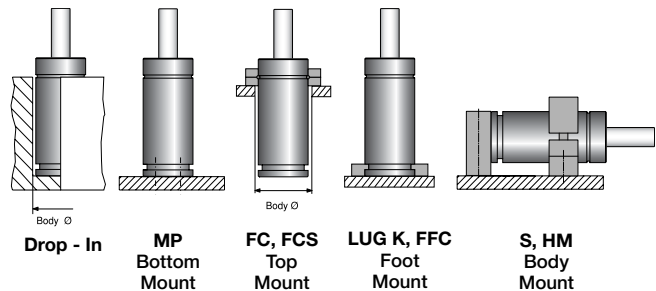

A business of BARNES GROUP INC

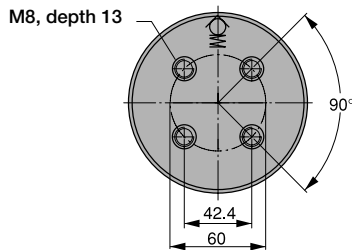
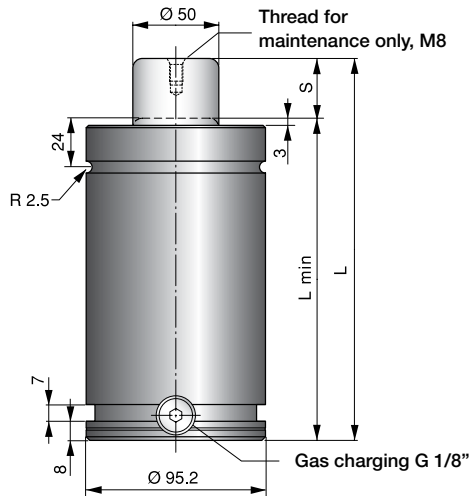

The basic line of gas springs is the TU line. Sizes 250 to 7500 correspond to the ISO 11901 standard for gas springs.

The thread in the piston rod top is to be used for maintenance only.

Millimeters to Inches: mm ÷ 25.4 = inches
Kilograms to Pounds: Kg ÷ 0.45 = pounds
Pounds Force to DecaNewtons: LbF x 0.4448 = decaNewtons

Order No.	S Stroke	Pounds Force (lbF) at 2175 psi		L ± 0.25	L min	Gas vol. (l)	Weight (kg)	ISO
		Initial	End force*					
TU 3000-025	25		9440	170	145	0.20	6.35	✓
TU 3000-038	38.1		9670	196.2	158.1	0.26	6.75	
TU 3000-050	50		9890	220	170	0.32	7.50	✓
TU 3000-063	63.5		10100	247	183.5	0.38	7.70	
TU 3000-075	75		10250	270	195	0.43	7.95	
TU 3000-080	80		10340	280	200	0.46	8.10	✓
TU 3000-100	100	6750	10570	320	220	0.56	8.85	✓
TU 3000-125	125		10570	370	245	0.69	9.90	✓
TU 3000-160	160		10570	440	280	0.87	10.80	✓
TU 3000-200	200		10790	520	320	1.07	12.20	
TU 3000-250	250		10790	620	370	1.32	13.7	
TU 3000-300	300		10790	720	420	1.57	15.3	

* = at full stroke

BASIC INFORMATION

Pressure medium Nitrogen
 Max. charging pressure 150 bar/2175 psi
 Min. charging pressure 25 bar/360 psi
 Operating temperature 0 - 80°C/0 - 176°F
 Force increase by temperature ±0.3%/°C
 Recommended max strokes/min ~ 15-40
 Max piston rod velocity 1.6 m/s
 Tube Black oxide
 Repair kits *New version (PED) 3019025
 Old version 2014068-03

*New version identified by circular rings on top of tube, guide and rod.

MOUNTING POSSIBILITIES

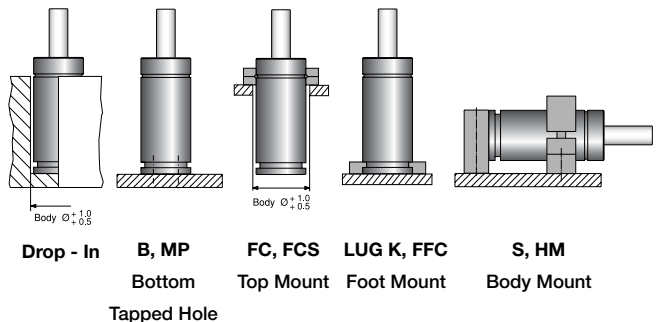

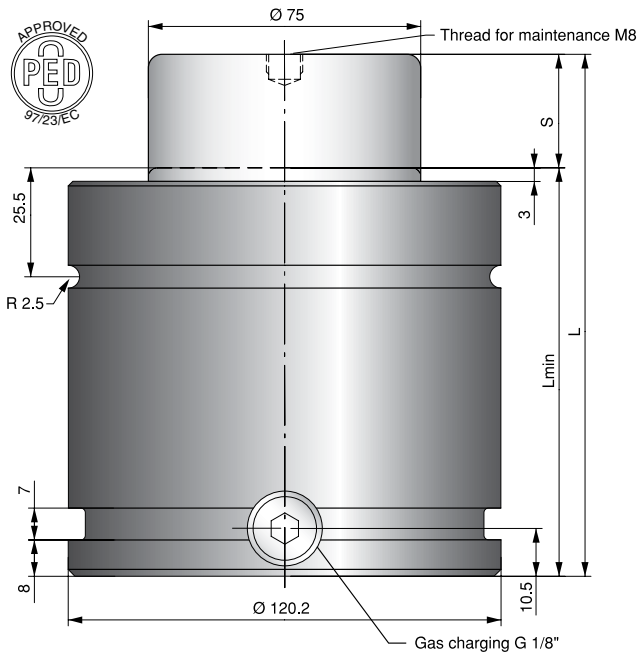

The Powerline gas springs are a new series.

These gas springs are our shortest, with more power to give you a great deal of force in a very small amount of space.

There is a side port for gas filling that can also be used to connect a hose system.

An upper C-groove, lower U-groove together with four M10 threaded holes allow various mounting possibilities using our standard mounts.

Millimeters to Inches: $mm \div 25.4 = \text{inches}$

Kilograms to Pounds: $Kg \div 0.45 = \text{pounds}$

Pounds Force to DecaNewtons:
 $LbF \times 0.4448 = \text{decaNewtons}$

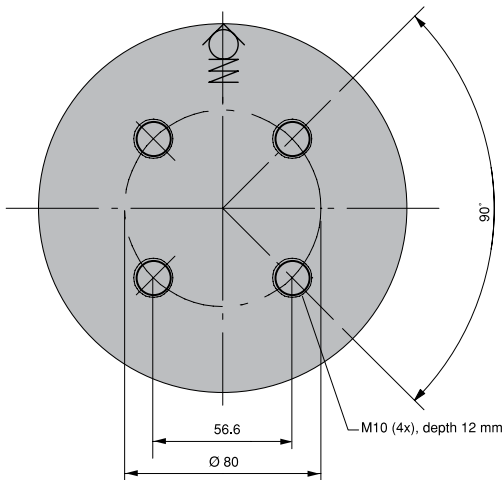

Order No.	S Stroke	Pounds Force (lbF) at 2175 psi		L ± 0.25	L min	Gas vol. (l)	Weight (kg)
		Initial	End force*				
X 6600-016	16	14905	20010	100	84	0.32	4.97
X 6600-019	19		20460	106	87	0.35	5.09
X 6600-025	25		21110	118	93	0.42	5.31
X 6600-032	32		21605	132	100	0.49	5.58
X 6600-038	38		22075	144	106	0.56	5.81
X 6600-050	50		22615	168	118	0.69	6.22
X 6600-063	63		23020	194	131	0.83	6.78
X 6600-075	75		23245	218	143	0.90	7.05
X 6600-080	80		23400	228	148	1.01	7.43
X 6600-100	100		23700	268	168	1.23	8.20
X 6600-125	125		23940	318	193	1.50	9.16

* = at full stroke

BASIC INFORMATION

Pressure medium Nitrogen
 Max. charging pressure 150 bar/2175 psi
 Min. charging pressure 25 bar/360 psi
 Operating temperature 0 - 80°C/0 - 176°F
 Force increase by temperature +0.3%/°C
 Recommended max strokes/min ~ 50-100
 Max piston rod velocity 1.6 m/s
 Tube Black oxide
 Repair kit X 6600

MOUNTING POSSIBILITIES

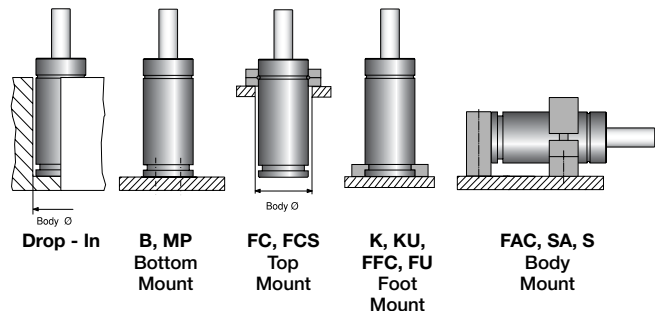

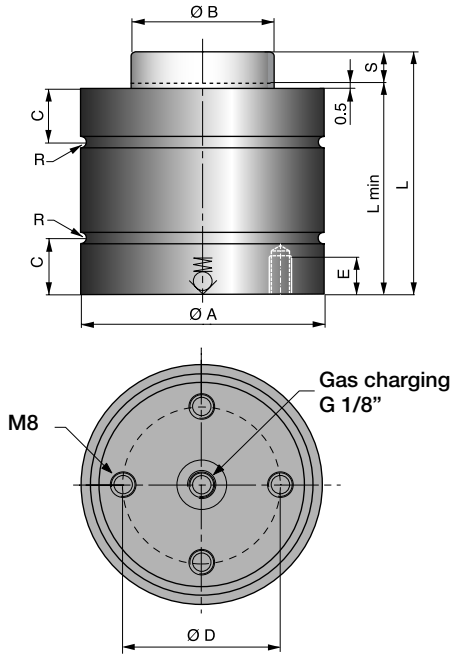

The CU gas spring is a very compact bore sealed gas spring, that gives a high force in a limited space. The max. frequency for the spring is 100 strokes/minute.

Springs with stroke lengths over 25 mm should always be attached to the tool, using a flange or the tapped holes in the bottom of the spring. We also recommend shorter stroke springs to be fastened for optimal service-life.

As an option, the CU springs can be delivered with a side-port plate for applications where a side port is needed, i.e. for use in hose systems.

Millimeters to Inches: mm ÷ 25.4 = inches
Kilograms to Pounds: Kg ÷ 0.45 = pounds
Pounds Force to DecaNewtons: LbF x 0.4448 = decaNewtons

Order No.	S Stroke	Pounds Force (lbF) at 2175 psi		L ± 0.25	L min	Ø A ± 0.1	Ø B	C	Ø D	E	R	Gas vol. (l)	Weight (kg)
		Initial	End force**										
CU 7500-010	10	16860	23400	90	80	95.2	55	21	52	9	1.5	0.18	2.8
CU 7500-016	16		23400	116	100							0.30	3.2
CU 7500-025	25		24500	145	120							0.41	3.7
CU 7500-032	32*		23600	182	150							0.57	4.4
CU 7500-040	40*		24000	210	170							0.68	4.8
CU 7500-050	50*		23800	255	205							0.87	5.6

* = Should always be attached to the tool using the tapped holes in the bottom or a flange
 ** = at full stroke

BASIC INFORMATION

Pressure medium..... Nitrogen
 Max. charging pressure 150 bar/2175 psi
 Min. charging pressure 25 bar/360 psi
 Operating temperature 0 - 80°C/0 - 176°F
 Force increase by temperature..... ±0.3%/°C
 Recommended max strokes/min..... ~80-100
 Max piston rod velocity..... 0.5 m/s
 Rod surface Black Nitride
 Tube surface Black Nitride
 Repair kit CU 7500

MOUNTING POSSIBILITIES

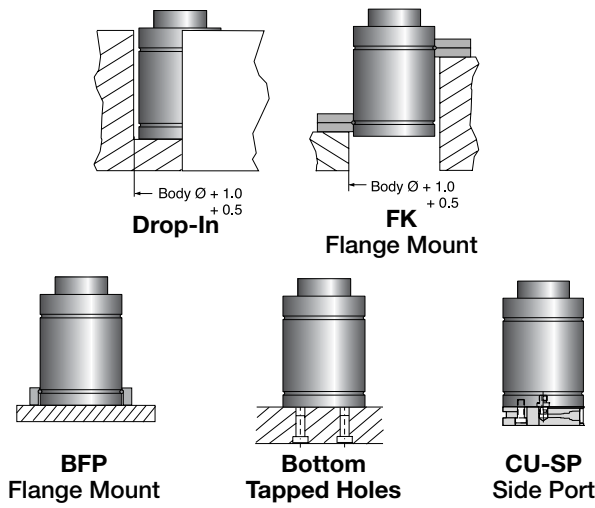

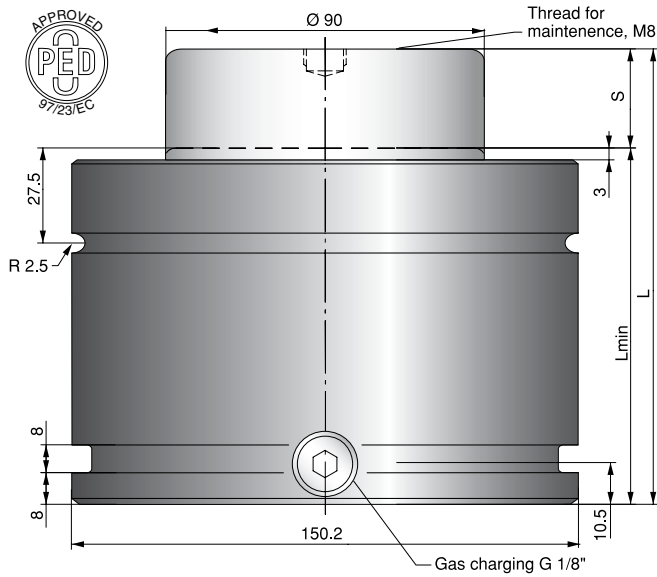

The Powerline gas springs are a new series.

These gas springs are our shortest, with more power to give you a great deal of force in a very small amount of space.

There is a side port for gas filling that can also be used to connect a hose system.

An upper C-groove, lower U-groove together with four M10 threaded holes allow various mounting possibilities using our standard mounts.

Millimeters to Inches: mm ÷ 25.4 = inches
Kilograms to Pounds: Kg ÷ 0.45 = pounds
Pounds Force to DecaNewtons: LbF x 0.4448 = decaNewtons

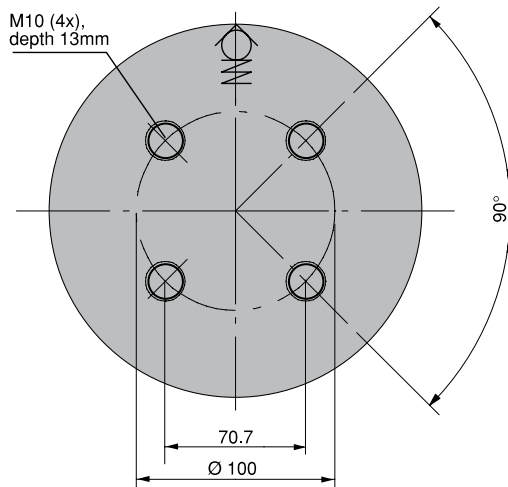

Order No.	S Stroke	Pounds Force (lbF) at 2175 psi		L ± 0.25	L min	Gas vol. (l)	Weight (kg)
		Initial	End force*				
X 9500-019	19	21400	30370	116	97	0.49	9.78
X 9500-025	25		31270	128	103	0.58	10.1
X 9500-032	32		31945	142	110	0.70	10.6
X 9500-038	38		32170	154	116	0.80	11.0
X 9500-050	50		32845	178	128	0.99	11.7
X 9500-063	63		33295	204	141	1.20	12.5
X 9500-075	75		33520	228	153	1.39	13.3
X 9500-080	80		33745	238	158	1.47	13.6
X 9500-100	100		33970	278	178	1.79	14.8
X 9500-125	125		34195	328	203	2.20	16.4

* = at full stroke

BASIC INFORMATION

Pressure medium Nitrogen
 Max. charging pressure 150 bar/2175 psi
 Min. charging pressure 25 bar/360 psi
 Operating temperature 0 - 80°C/0 - 176°F
 Force increase by temperature +0.3%/°C
 Recommended max strokes/min ~ 50-100
 Max piston rod velocity 1.6 m/s
 Tube Black oxide
 Repair kit X 9500

MOUNTING POSSIBILITIES

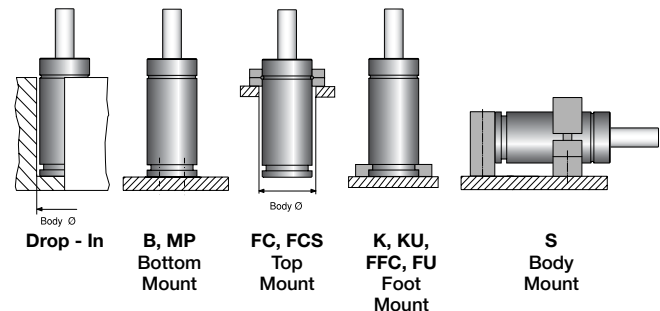

A business of BARNES GROUP INC

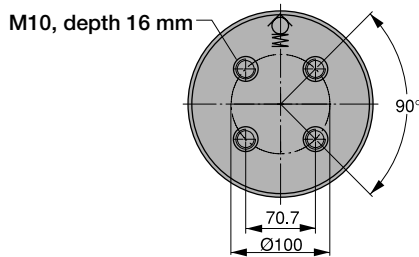
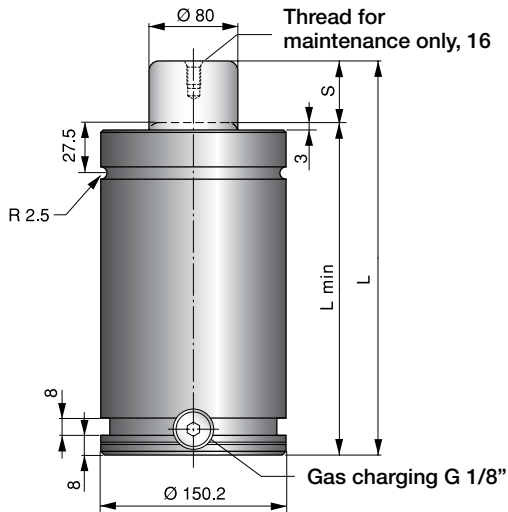

The basic line of gas springs is the TU line. Sizes 250 to 7500 correspond to the ISO 11901 standard for gas springs.

The thread in the piston rod top is to be used for maintenance only.

Millimeters to Inches: mm ÷ 25.4 = inches
Kilograms to Pounds: Kg ÷ 0.45 = pounds
Pounds Force to DecaNewtons: LbF x 0.4448 = decaNewtons

Order No.	S Stroke	Pounds Force (lbF) at 2175 psi		L ± 0.25	L min	Gas vol. (l)	Weight (kg)	ISO
		Initial	End Force*					
TU 7500-025	25		23600	205	180	0.51	19.2	✓
TU 7500-038	38.1		24730	231.2	193.1	0.67	20.0	
TU 7500-050	50		25400	255	205	0.81	20.9	✓
TU 7500-063	63.5		25850	282	218.5	0.98	21.8	
TU 7500-075	75		26150	305	230	1.11	22.5	
TU 7500-080	80		26300	315	235	1.18	22.9	✓
TU 7500-100	100	16860	26750	355	255	1.43	24.3	✓
TU 7500-125	125		27200	405	280	1.74	26.0	✓
TU 7500-160	160		27430	475	315	2.17	28.4	✓
TU 7500-200	200		27650	555	355	2.66	31.1	
TU 7500-250	250		27880	655	405	3.27	34.5	
TU 7500-300	300		27880	755	455	3.88	37.9	

* = at full stroke

BASIC INFORMATION

Pressure mediumNitrogen
 Max. charging pressure 150 bar/2175 psi
 Min. charging pressure 25 bar/360 psi
 Operating temperature 0 - 80°C/0 - 176°F
 Force increase by temperature ±0.3%/°C
 Recommended max strokes/min ~ 15-40
 Max piston rod velocity 1.6 m/s
 TubeBlack oxide
 Repair kits *New version (PED) 3018877
 Old version 2014068-09

*New version identified by circular rings on top of tube, guide and rod.

MOUNTING POSSIBILITIES

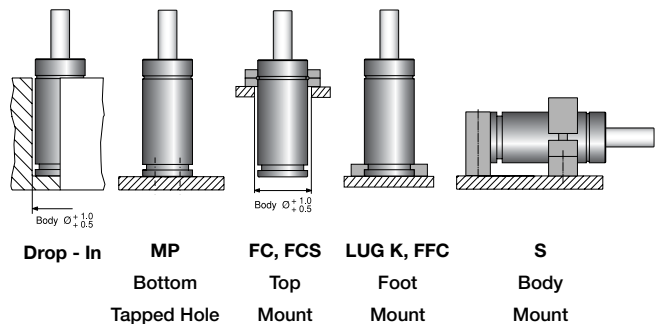

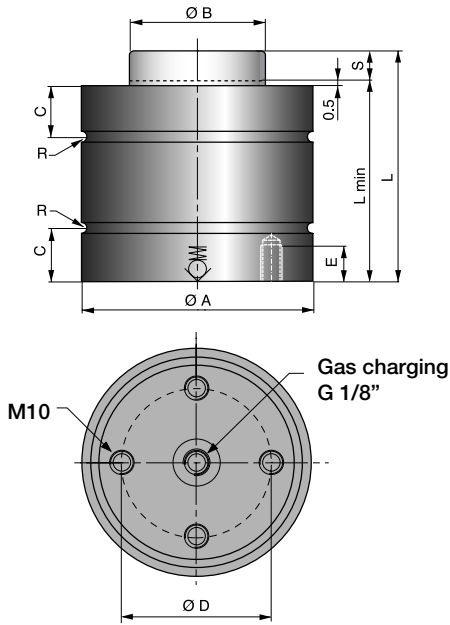

The CU gas spring is a very compact bore sealed gas spring, that gives a high force in a limited space.
The max. frequency for the spring is 100 strokes/minute.

Springs with stroke lengths over 25 mm should always be attached to the tool, using a flange or the tapped holes in the bottom of the spring. We also recommend shorter stroke springs to be fastened for optimal service-life.

As an option, the CU springs can be delivered with a side-port plate for applications where a side port is needed, i.e. for use in hose systems.

Millimeters to Inches: mm ÷ 25.4 = inches
Kilograms to Pounds: Kg ÷ 0.45 = pounds
Pounds Force to DecaNewtons: LbF x 0.4448 = decaNewtons

Order No.	S Stroke	Pounds Force (lbF) at 2175 psi		L ± 0.25	L min	Ø A ± 0.1	Ø B	C	Ø D	E	R	Gas vol. (l)	Weight (kg)
		Initial	End force**										
CU 11800-010	10		34800	100	90							0.33	5.4
CU 11800-016	16		35500	126	110							0.50	6.0
CU 11800-025	25	26530	38200	155	130	120.2	70	22.5	68	11	2.5	0.68	6.9
CU 11800-032	32*		36900	187	155							0.88	7.8
CU 11800-040	40*		37100	220	180							1.00	8.7
CU 11800-050	50*		37300	260	210							1.35	9.9
CU 18300-010	10		52800	110	100							0.56	9.5
CU 18300-016	16		56600	136	120							0.84	10.4
CU 18300-025	25	41140	57100	165	140	150.2	90	24.5	90	11	2.5	1.13	11.8
CU 18300-032	32*		56400	197	165							1.45	13.3
CU 18300-040	40*		56200	235	195							1.86	15.0
CU 18300-050	50*		57300	270	220							2.19	16.5

* = Should always be attached to the tool using the tapped holes in the bottom or a flange
 ** = at full stroke

BASIC INFORMATION

Pressure medium.....Nitrogen
 Max. charging pressure 150 bar/2175 psi
 Min. charging pressure 25 bar/360 psi
 Operating temperature 0 - 80°C/0 - 176°F
 Force increase by temperature..... ±0.3%/°C
 Recommended max strokes/min.....~80-100
 Max piston rod velocity.....0.8 m/s
 Rod surfaceBlack Nitride
 Tube surfaceBlack Nitride
 Repair kit CU 11800
 Repair kit CU 18300

MOUNTING POSSIBILITIES

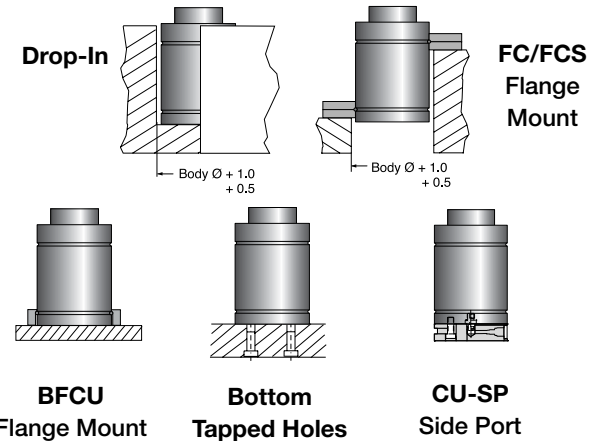

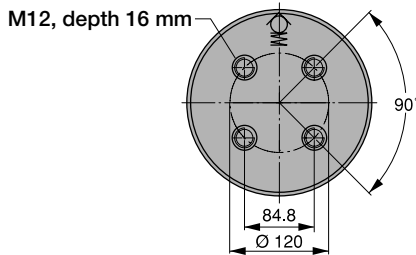
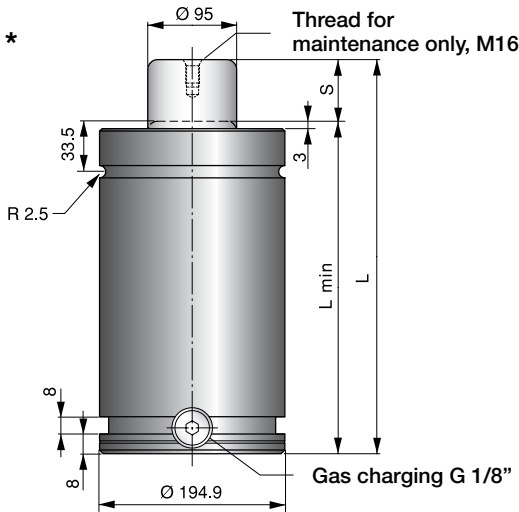

* TU 10000's outer dimensions according to ISO 11901 standard.

The thread in the piston rod top is to be used for maintenance only.

Millimeters to Inches: mm ÷ 25.4 = inches
Kilograms to Pounds: Kg ÷ 0.45 = pounds
Pounds Force to DecaNewtons: LbF x 0.4448 = decaNewtons

Order No.	S Stroke	Pounds Force (lbF) at 2175 psi		L ± 0.25	L min	Gas vol. (l)	Weight (kg)	ISO
		Initial	End force**					
TU 10000-025	25		31020	210	185	0.87	36.5	
TU 10000-038	38.1		32150	236.2	198.1	1.13	38.5	
TU 10000-050	50		33050	260	210	1.37	40.0	✓
TU 10000-063	63.5		33720	287	223.5	1.64	42.0	
TU 10000-080	80		34170	320	240	1.98	44.0	✓
TU 10000-100	100	23830	35070	360	260	2.38	46.5	✓
TU 10000-125	125		35300	410	285	2.88	50.0	✓
TU 10000-160	160		35520	480	320	3.59	54.5	✓
TU 10000-200	200		35970	560	360	4.39	60.0	✓
TU 10000-250	250		35970	660	410	5.40	66.5	✓
TU 10000-300	300		35970	760	460	6.40	73.0	✓

** = at full stroke

BASIC INFORMATION

Pressure medium Nitrogen
 Max. charging pressure 150 bar/2175 psi
 Min. charging pressure 25 bar/360 psi
 Operating temperature 0 - 80°C/0 - 176°F
 Force increase by temperature +0.3%/°C
 Recommended max strokes/min ~ 15-40
 Max piston rod velocity 1.6 m/s
 Tube Black oxide
 Repair kit TU 10000

MOUNTING POSSIBILITIES

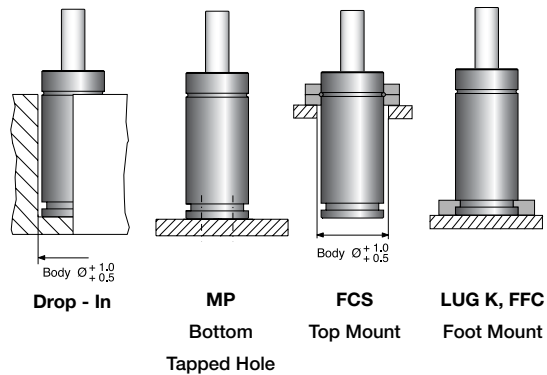

The Ford Motor Company has their own WDX3560 World Standard for gas springs, mounts and accessories supplied to Ford, based on the KALLER TU and LCF series.

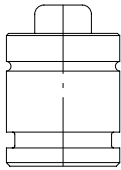

WDX356015-XX-XX-DMS¹, (TU 750-7500)
WDX356025-XX-XX-DMS¹, (LCF 750-7500)
¹= Self contained (S) only

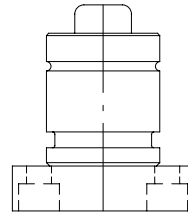

WDX356016-XX-XX-PM⁽¹⁾, (TU 750-7500 with MP plate)
¹= Self contained (S) or Piped system (P).
Note! Piped system (P) supplied with adapter 4017764.

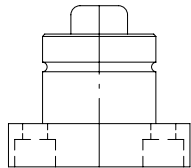

WDX356017-XX-XX-SW⁽¹⁾, (TU 750-7500 with square welded flange)
WDX356026-XX-XX-SM⁽¹⁾ (LCF 750-7500 with square welded flange)
¹= Self contained (S) or Piped system (P).
Note! Piped system (P) supplied with adapter 4017764.

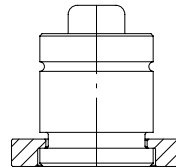

WDX356018-XX-XX-SLS¹, (TU 750-7500 with FFC³ flange)
¹= Self contained (S) only
³= 750 size requires special FFC flange.

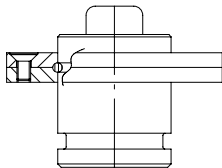

WDX3560019-XX-XX-TMS⁽¹⁾, (TU 750-7500 with FC⁴ flange)
¹= Self contained (S) only
⁴= 750 size requires special FC flange.

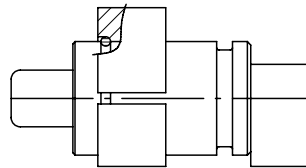

WDX3560020-XX-XX-HM⁽¹⁾, (TU 750-3000 with horizontal foot mount)
¹= Self contained (S) or Piped system (P).
Note! Piped system (P) supplied with adapter 4017764.

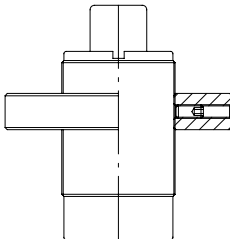

WDX3560021-07-XX-TB, (KM 750 with FTM 750 mount)

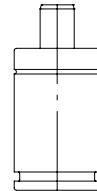

WDX3560022-03-XX-DM, (TU 250)

General Motors has their own M-1500 North American Standard and 90.25 Global Die Standard for gas springs, mounts and accessories supplied to GM, based on the KALLER TU series.

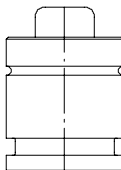

M1500-XX-XX, (TU 750-7500)
90.25.00-XX-XX, (TU 750-7500)

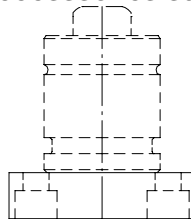

M1501-XX-01, (Mount only , MP plate 750-7500)
90.25.04-XX, (Mount only , MP plate 750-7500)

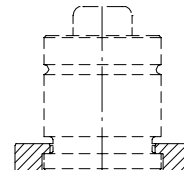

M1501-XX-02, (Mount only , FFC-flange 750-7500)
90.25.01-XX, (Mount only , FFC-flange 750-7500)

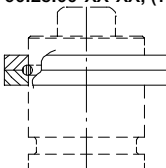

M1501-XX-03, (Mount only, FCS-flange 750-7500)
90.25.02-XX, (Mount only, FCS-flange 750-7500)

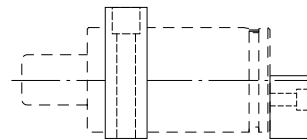

M1501-XX-04, (Mount only, Horizontal foot mount 750-3000)
90.25.06-XX, (Mount only, Horizontal foot mount 750-3000)



Designed for a long life while maintaining consistent, repeatable loads, Raymond Mechanical Spring Struts are the ideal choice to replace conventional gas springs. They will withstand harsh environments and wide temperature ranges, and offer a variety of loads, strokes and end configurations. The units utilize advanced coiled spring technology, along with engineered components, to provide a low-friction, highly reliable product.

Raymond Mechanical Spring Struts are offered in a full range of standard struts featuring stainless steel springs, and high load struts with carbon steel springs. In addition, our mechanical spring struts and assembly modules can be custom designed to meet the specific needs of many products within a wide range of industries.

Mechanical Spring Struts Are The Better Choice

- Long life and consistent loads over time
- Corrosion-resistant stainless steel construction
- Design flexibility to meet individual requirements
- No internal gases or seals – no hazardous material concerns
- Proven for FDA applications
- Robust design
- Various end configurations available
- Operating temperatures up to 400°F
- Extension and dampening units offer additional flexibility

STRUTS FOR MANY INDUSTRIES

Automotive	Marine
Recreational	Industrial
Medical	Nuclear
Pharmaceutical	Chemical
Defense	Agriculture
Construction	

STRUTS FOR MANY APPLICATIONS

Food Preparation & Processing
Heating, Ventilation & Aeration
Motion Control & Dampening



Select From A Wide Range Of Mechanical Spring Struts – Or We’ll Design One For You

STANDARD MECHANICAL SPRING STRUTS (Stainless Steel Construction – Stainless Steel Springs – M6 Ends)

CATALOG NUMBER	Rod Dia. (d)		Body Dia. (D)		Overall Length (L) +/-0.060"		Stroke (S) +/-0.060"		Initial Force +/-10%		Final Force +/-10%	
	in	mm	in	mm	in	mm	in	mm	lbs	N	lbs	N
MSBD-051-0076	0.375	9.53	1.25	31.75	6.95	176.53	2.00	50.80	8	35	17	76
MSBD-051-0116	0.375	9.53	1.25	31.75	8.44	214.38	2.00	50.80	19	85	26	116
MSBD-051-0173	0.375	9.53	1.25	31.75	9.99	253.75	2.00	50.80	30	133	39	173
MSBD-051-0280	0.375	9.53	1.25	31.75	11.61	294.89	2.00	50.80	45	200	63	280
MSBD-076-0102	0.375	9.53	1.25	31.75	9.56	242.82	3.00	76.20	10	44	23	102
MSBD-076-0156	0.375	9.53	1.25	31.75	10.3	261.62	3.00	76.20	15	67	35	156
MSBD-076-0262	0.375	9.53	1.25	31.75	12.26	311.40	3.00	76.20	30	133	59	262
MSBD-127-0133	0.375	9.53	1.25	31.75	17.02	432.31	5.00	127.00	18	80	30	133
MSBD-127-0173	0.375	9.53	1.25	31.75	18.67	474.22	5.00	127.00	25	111	39	173
MSBD-127-0222	0.375	9.53	1.25	31.75	18.96	481.58	5.00	127.00	30	133	50	222
MSBD-127-0271	0.375	9.53	1.25	31.75	19.91	505.71	5.00	127.00	35	156	61	271



Multiple end configurations, including ball ends, blade or clevis ends are available in various sizes and materials



Design and assembly of adjoining hardware (including brackets and mounts) is also offered per customer requirement.

HIGH LOAD MECHANICAL SPRING STRUTS (Stainless Steel Construction – Carbon Steel Springs – M8 Ends)

CATALOG NUMBER	Rod Dia. (d)		Body Dia. (D)		Overall Length (L) +/-0.060"		Stroke (S) +/-0.060"		Initial Force +/-10%		Final Force +/-10%	
	in	mm	in	mm	in	mm	in	mm	lbs	N	lbs	N
MSCD-026-1057	0.500	12.7	1.25	31.75	7.44	188.98	1.04	26.42	176	782	238	1057
MSCD-026-1240	0.500	12.7	1.25	31.75	5.95	151.13	1.04	26.42	83	369	279	1240
MSCD-033-1069	0.500	12.7	1.25	31.75	6.25	158.75	1.31	33.27	100	446	240	1069
MSCD-039-1072	0.500	12.7	1.25	31.75	6.55	166.37	1.56	39.62	53	236	241	1072
MSCD-039-1111	0.500	12.7	1.25	31.75	7.94	201.68	1.54	39.12	140	622	250	1111
MSCD-041-2354	0.500	12.7	1.25	31.75	13.62	345.95	1.63	41.40	242	1075	529	2354
MSCD-043-2187	0.500	12.7	1.25	31.75	9.69	246.13	1.70	43.18	94	417	492	2187
MSCD-055-1170	0.500	12.7	1.25	31.75	10.19	258.83	2.19	55.63	41	181	263	1170
MSCD-077-1150	0.500	12.7	1.25	31.75	15.12	384.05	3.07	77.98	80	355	259	1150
MSCD-078-1111	0.500	12.7	1.25	31.75	11.09	281.69	3.10	78.74	29	127	250	1111
MSCD-117-1067	0.500	12.7	1.25	31.75	16.62	422.15	4.63	117.60	55	244	240	1067

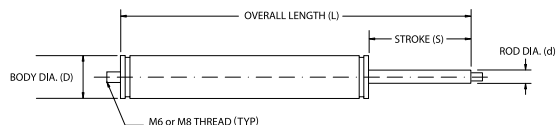
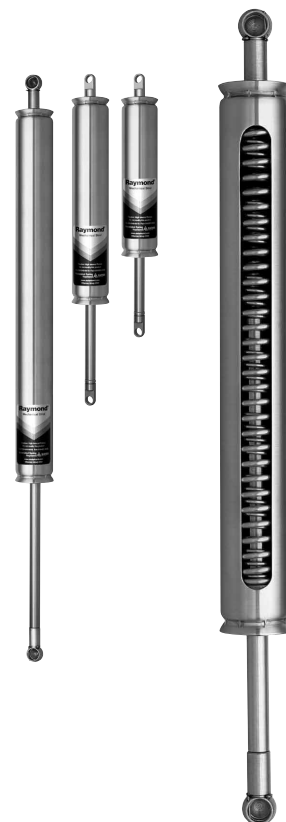

BLADE END (STAINLESS STEEL)

Suffix		A		B	
		in	mm	in	mm
10	M6	0.71	18.00	0.26	6.70
11	M8	0.85	21.70	0.34	8.70

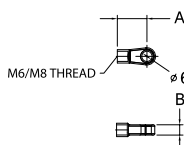

10 MM BALL END (NYLON)

Suffix		Ball Size	A (REF)	
			in	mm
30	M6	10mm	0.709	18.01
31	M8	10mm	0.709	18.01

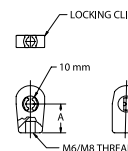

CLEVIS (STAINLESS STEEL)

Suffix		A	
		in	mm
40	M6	0.94	24.00
41	M8	1.25	32.00

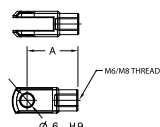

BALL STUD (STAINLESS STEEL)

Suffix		A (REF)		B		C	
		in	mm	in	mm	in	mm
50	M6	0.39	10.00	0.43	11.00	0.47	12.00
51	M8	0.51	13.00	0.51	13.00	0.65	16.50

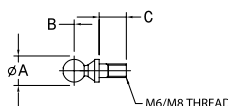

BALL END (STAINLESS STEEL)

Suffix		Ball Size	A (REF)	
			in	mm
20	M6	10mm	1.00	25.40
21	M8	10mm	1.18	30.00

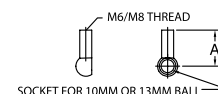

NOTE: To order a Mechanical Spring Strut with the ends attached, the end suffix must be added to the part number. For example: To order a Mechanical Spring Strut with a blade end on the rod end and a stainless ball end on the strut end, specify MSBD-076-0102-10-20.

We reserve the right to add, delete or modify components without notification.
All dimensions are stated in mm.
All dimensions are nominal unless tolerance is stated.

STANDARD MECHANICAL EXTENSION STRUTS (Stainless Steel Construction - Stainless Steel Springs - M6 Ends)

CATALOG NUMBER	Rod Dia. (d)		Body Dia. (D)		Overall Length (L)		Extended Length Ref. (L1)		Stroke (S)		Initial Force +/-10%		Final Force +/-10%	
	in	mm	in	mm	in	mm	in	mm	in	mm	Lbs	N	Lbs	N
MEBD-051-0076	0.38	9.53	1.25	31.75	4.95	125.73	6.95	176.53	2.0	50.80	8	35	17	76
MEBD-051-0116	0.38	9.53	1.25	31.75	6.44	163.58	8.44	214.38	2.0	50.80	19	85	26	116
MEBD-051-0173	0.38	9.53	1.25	31.75	7.99	202.95	9.99	253.75	2.0	50.80	30	133	39	173
MEBD-051-0280	0.38	9.53	1.25	31.75	9.61	244.09	11.61	294.89	2.0	50.80	45	200	63	280
MEBD-076-0102	0.38	9.53	1.25	31.75	6.56	166.62	9.56	242.82	3.0	76.20	10	44	23	102
MEBD-076-0156	0.38	9.53	1.25	31.75	7.30	185.42	10.30	261.62	3.0	76.20	15	67	35	156
MEBD-076-0262	0.38	9.53	1.25	31.75	9.26	235.20	12.26	311.40	3.0	76.20	30	133	59	262
MEBD-127-0133	0.38	9.53	1.25	31.75	12.02	305.31	17.02	432.31	5.0	127.00	18	80	30	133
MEBD-127-0173	0.38	9.53	1.25	31.75	13.67	347.22	18.67	474.22	5.0	127.00	25	111	39	173
MEBD-127-0222	0.38	9.53	1.25	31.75	13.96	354.58	18.96	481.58	5.0	127.00	30	133	50	222
MEBD-127-0271	0.38	9.53	1.25	31.75	14.91	378.71	19.91	505.71	5.0	127.00	35	156	61	271

HIGH LOAD MECHANICAL EXTENSION STRUTS (Stainless Steel Construction - Carbon Steel Springs - M8 Ends)

CATALOG NUMBER	Rod Dia. (d)		Body Dia. (D)		Overall Length (L)		Extended Length Ref. (L1)		Stroke (S)		Initial Force +/-10%		Final Force +/-10%	
	in	mm	in	mm	in	mm	in	mm	in	mm	Lbs	N	Lbs	N
MECD-026-1057	0.50	12.70	1.25	31.75	6.44	163.58	7.44	188.98	1.0	25.40	176	782	238	1057
MECD-026-1240	0.50	12.70	1.25	31.75	4.95	125.73	5.95	151.13	1.0	25.40	83	369	279	1240
MECD-033-1069	0.50	12.70	1.25	31.75	4.95	125.73	6.25	158.75	1.3	33.02	100	446	240	1069
MECD-039-1072	0.50	12.70	1.25	31.75	4.95	125.73	6.55	166.37	1.6	40.64	53	236	241	1072
MECD-039-1111	0.50	12.70	1.25	31.75	6.44	163.58	7.94	201.68	1.5	38.10	140	622	250	1111
MECD-041-2354	0.50	12.70	1.25	31.75	12.02	305.31	13.62	345.95	1.6	40.64	242	1075	529	2354
MECD-043-2187	0.50	12.70	1.25	31.75	7.99	202.95	9.69	246.13	1.7	43.18	94	417	492	2187
MECD-055-1170	0.50	12.70	1.25	31.75	7.99	202.95	10.19	258.83	2.2	55.88	41	181	263	1170
MECD-077-1150	0.50	12.70	1.25	31.75	12.02	305.31	15.12	384.05	3.1	78.74	80	355	259	1150
MECD-078-1111	0.50	12.70	1.25	31.75	7.99	202.95	11.09	281.69	3.1	78.74	29	127	250	1111
MECD-117-1067	0.50	12.70	1.25	31.75	12.02	305.31	16.62	422.15	4.6	116.84	55	244	240	1067

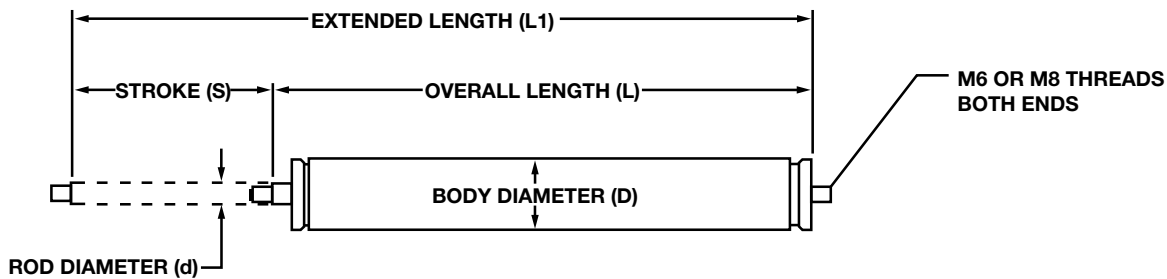

Mechanical Self-Centering Spring Struts

STANDARD MECHANICAL SELF-CENTERING STRUTS (Stainless Steel Construction - Stainless Steel Springs - M6 Ends)

CATALOG NUMBER	Rod Dia. (d)		Body Dia. (D)		Overall Length (L)		Stroke (S)		Extended Length Ref. (L1)		Compressed Length (L2)		Initial Force +/-10%		Final Force +/-10%	
	in	mm	in	mm	in	mm	in	mm	in	mm	in	mm	Lbs	N	Lbs	N
MCBD-051-0076	0.38	9.53	1.25	31.75	10.45	265.37	2.0	50.8	12.45	316.2	8.45	214.6	8	35	17	76
MCBD-051-0116	0.38	9.53	1.25	31.75	13.42	340.96	2.0	50.8	15.42	391.8	11.42	290.2	19	85	26	116
MCBD-051-0173	0.38	9.53	1.25	31.75	9.93	252.16	2.0	50.8	11.93	303.0	7.93	201.4	30	133	39	173
MCBD-051-0280	0.38	9.53	1.25	31.75	19.77	502.20	2.0	50.8	21.77	553.0	17.77	451.4	45	200	63	280
MCBD-076-0102	0.38	9.53	1.25	31.75	14.67	372.61	3.0	76.2	17.67	448.8	11.67	296.4	10	44	23	102
MCBD-076-0156	0.38	9.53	1.25	31.75	16.15	410.15	3.0	76.2	19.15	486.3	13.15	333.9	15	67	35	156
MCBD-076-0262	0.38	9.53	1.25	31.75	20.07	509.71	3.0	76.2	23.07	585.9	17.07	433.5	30	133	59	262
MCBD-127-0133	0.38	9.53	1.25	31.75	27.59	700.72	5.0	127.0	32.59	827.7	22.59	573.7	18	80	30	133
MCBD-127-0173	0.38	9.53	1.25	31.75	30.89	784.54	5.0	127.0	35.89	911.5	25.89	657.5	25	111	39	173
MCBD-127-0222	0.38	9.53	1.25	31.75	31.47	799.38	5.0	127.0	36.47	926.4	26.47	672.4	30	133	50	222
MCBD-127-0271	0.38	9.53	1.25	31.75	33.36	847.46	5.0	127.0	38.36	974.5	28.36	720.5	35	156	61	271

HIGH LOAD MECHANICAL SELF-CENTERING STRUTS (Stainless Steel Construction - Carbon Steel Springs - M8 Ends)

CATALOG NUMBER	Rod Dia. (d)		Body Dia. (D)		Overall Length (L)		Stroke (S)		Extended Length Ref. (L1)		Compressed Length (L2)		Initial Force +/-10%		Final Force +/-10%	
	in	mm	in	mm	in	mm	in	mm	in	mm	in	mm	Lbs	N	Lbs	N
MCCD-026-1057	0.50	12.70	1.25	31.75	12.42	315.40	1.0	25.4	13.42	340.8	11.42	290.0	176	782	238	1057
MCCD-026-1240	0.50	12.70	1.25	31.75	9.45	239.97	1.0	25.4	10.45	265.4	8.45	214.6	83	369	279	1240
MCCD-033-1069	0.50	12.70	1.25	31.75	9.75	247.59	1.3	33.0	11.05	280.6	8.45	214.6	100	446	240	1069
MCCD-039-1072	0.50	12.70	1.25	31.75	10.05	255.21	1.6	40.6	11.65	295.8	8.45	214.6	53	236	241	1072
MCCD-039-1111	0.50	12.70	1.25	31.75	12.92	328.10	1.5	38.1	14.42	366.2	11.42	290.0	140	622	250	1111
MCCD-041-2354	0.50	12.70	1.25	31.75	24.19	614.36	1.6	40.6	25.79	655.0	22.59	573.7	242	1075	529	2354
MCCD-043-2187	0.50	12.70	1.25	31.75	16.23	412.18	1.7	43.2	17.93	455.4	14.53	369.0	94	417	492	2187
MCCD-055-1170	0.50	12.70	1.25	31.75	16.73	424.88	2.2	55.9	18.93	480.8	14.53	369.0	41	181	263	1170
MCCD-077-1150	0.50	12.70	1.25	31.75	25.69	652.46	3.1	78.7	28.79	731.2	22.59	573.7	80	355	259	1150
MCCD-078-1111	0.50	12.70	1.25	31.75	17.63	447.74	3.1	78.7	20.73	526.5	14.53	369.0	29	127	250	1111
MCCD-117-1067	0.50	12.70	1.25	31.75	27.19	690.56	4.6	116.8	31.79	807.4	22.59	573.7	55	244	240	1067

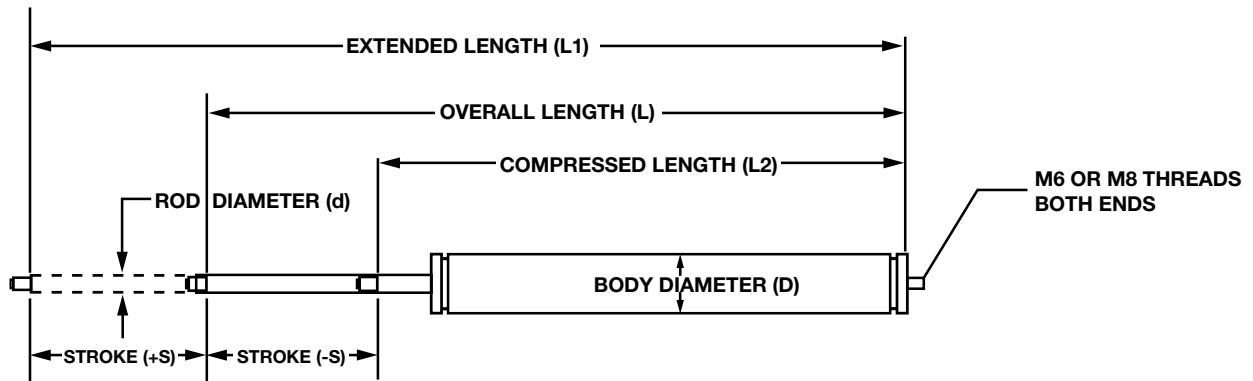

Compression Strut

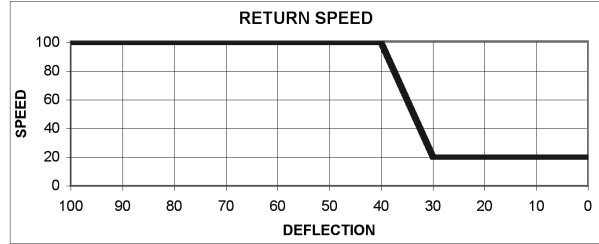
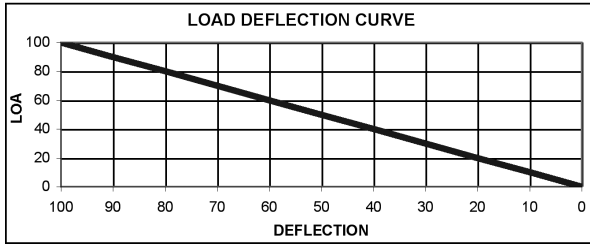

Provides a linear increasing load during compression and fast return speed to original extended position.
Note: Application & system balance ultimately controls the return speed in both compression and extension.

Extension Strut

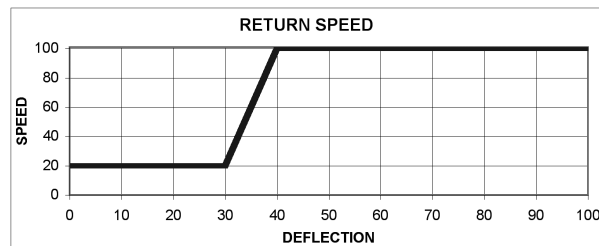
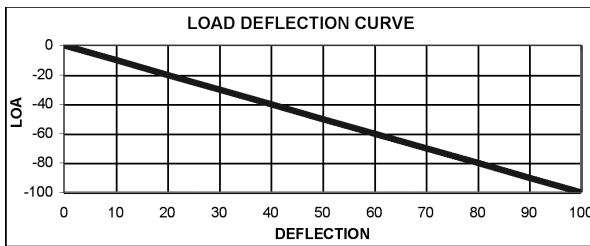

Provides a linear increasing load during extension with an unrestricted return speed to original compressed position.
Note: Application & system balance ultimately controls the return speed in both compression and extension.

Self-Centering Strut

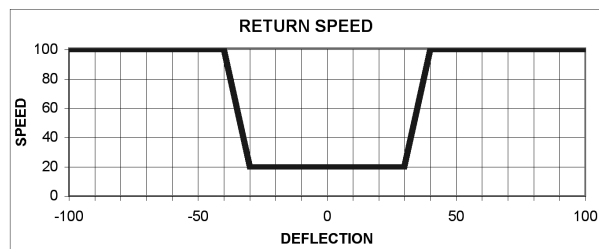
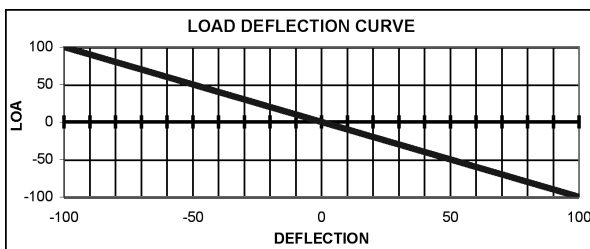

Provides a linear increasing loads in both directions from a neutral/centered position with an unrestricted return speed to the neutral/center position.
Note: Application & system balance ultimately controls the return speed in both compression and extension.

NOTE: RETURN SPEED GRAPHS ILLUSTRATE "SPEED CONTROLLED" PROFILES. PLEASE SPECIFY WHEN ORDERING

Beyond our standard catalog range, Raymond offers numerous custom m-Struts® to fit the end user particular application. The following graphs covering Telescoping, Locking, Over-Center, Dampened and Variable Rate mechanical struts are examples of products developed for specific applications, and showcase the capabilities and versatility presented by this product line.

Telescoping Strut

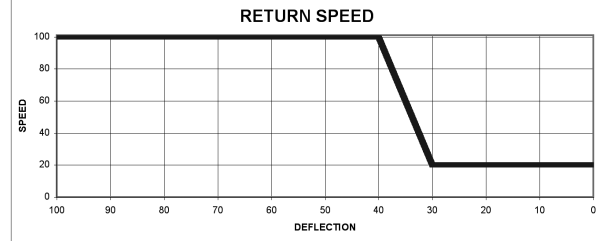
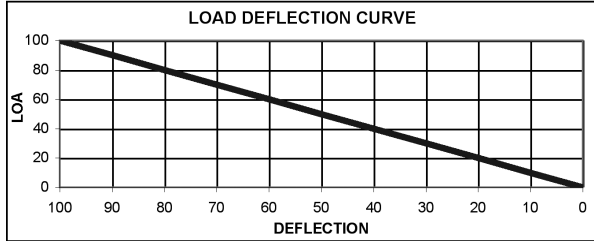

Provides a linear increasing load during compression and fast return speed to original extended position. Construction allows maximum achievable loads in limited application space.

Note: Application & system balance ultimately controls the return speed in both compression and extension.

Locking Strut

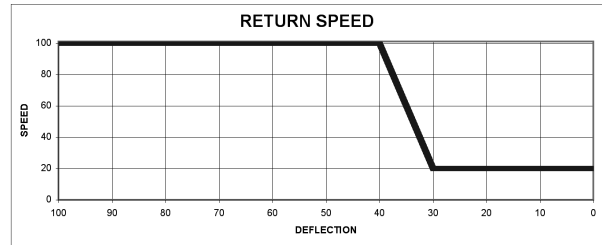
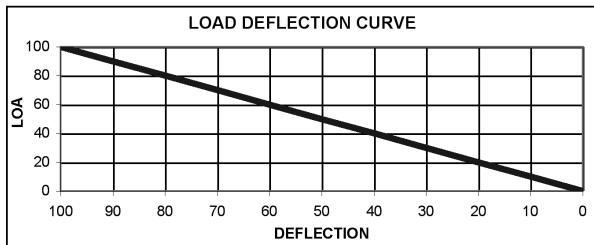

Provides a linear increasing load during compression, fast return speed to original extended position and a positive hold open lock.

Note: Application & system balance ultimately controls the return speed in both compression and extension.

Over-Centering Strut

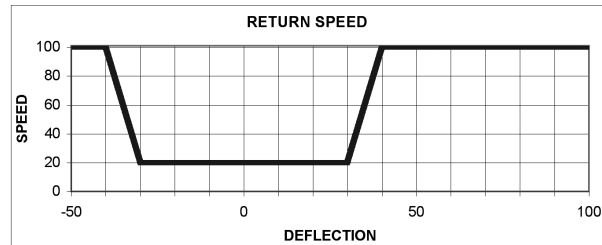
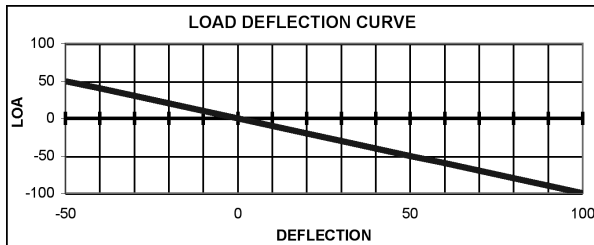

Provides a linear increasing loads in both directions from a specific neutral position with an unrestricted return speed to the neutral position.

Note: Application & system balance ultimately controls the return speed in both compression and extension.

NOTE: RETURN SPEED GRAPHS ILLUSTRATE "SPEED CONTROLLED" PROFILES. PLEASE SPECIFY WHEN ORDERING

Spring-Over Damper (Compression)

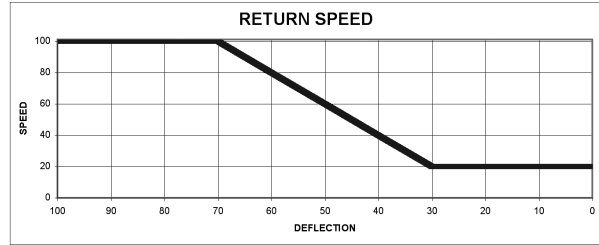
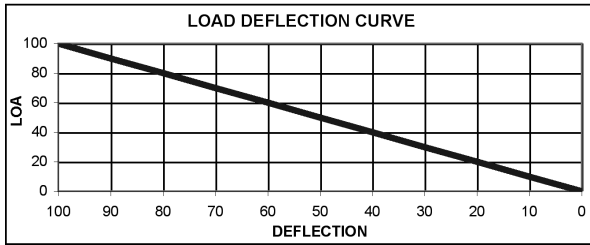

Provides a linear increasing load during compression and a controlled return speed to original extended position.

Note: Application, system balance and internal dampening mechanism controls the return speed to the extended position.

Spring-Over Damper (Extension)

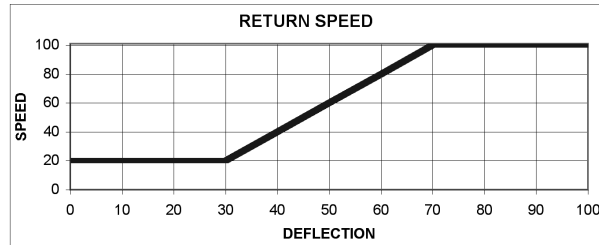
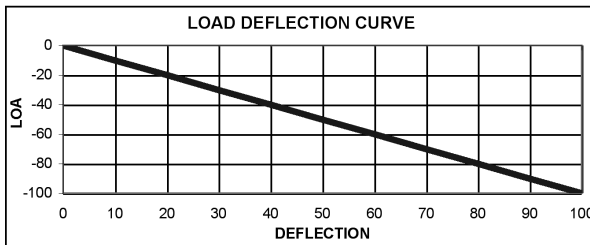

Provides a linear increasing load during extension and a controlled return speed to original compressed position.

Note: Application, system balance and internal dampening mechanism controls the return speed to the compressed position.

Variable Rate Compression

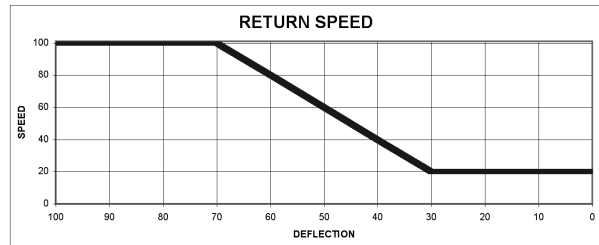
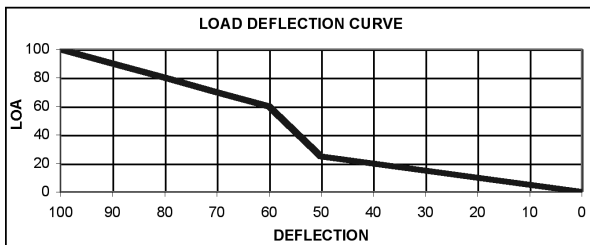

Provides a step functioned linear increasing load during compression and a controlled return speed to original extended position.

Note: Application and system balance controls the return speed to the extended position.

NOTE: RETURN SPEED GRAPHS ILLUSTRATE "SPEED CONTROLLED" PROFILES. PLEASE SPECIFY WHEN ORDERING

Variable Rate (Extension)

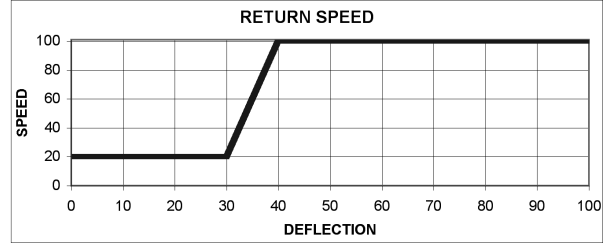
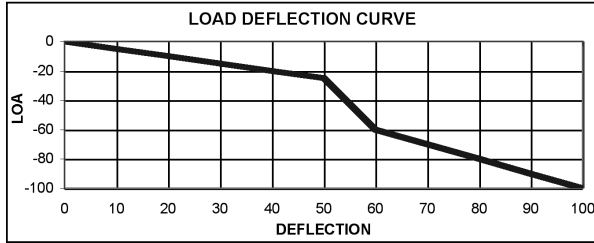

Provides a step functioned linear increasing load during extension and a controlled return speed to original compressed position.

Note: Application and system balance controls the return speed to the extended position.

Speed Controlled Compressions Strut (Single Step Function)

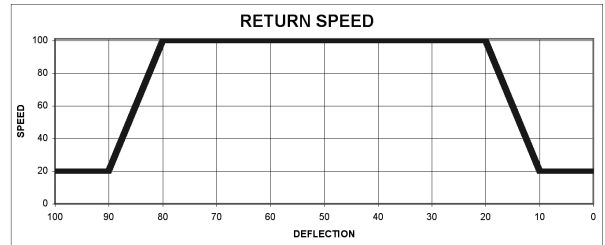
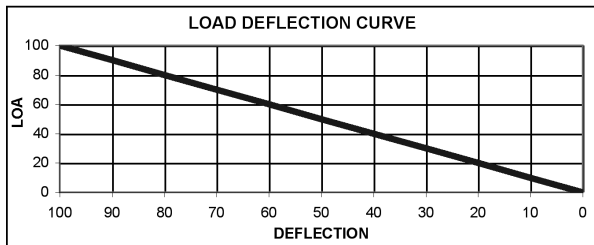

Provides a self contained system with linear increasing load during compression and a controlled return speed to original extended position.

Note: Application, system balance and internal dampening mechanism controls the return speed to the extended position.

Speed Controlled Compressions Strut (Multiple Step Function)

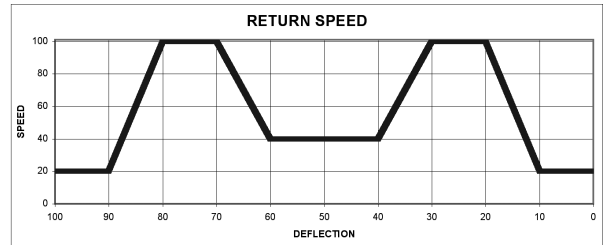
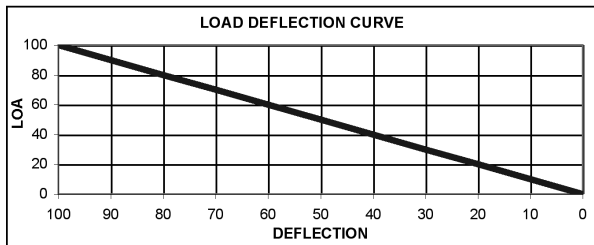

Provides a self contained system with a step functioned linear increasing load during extension and a controlled return speed to original extended position.

Note: Application, system balance and internal dampening mechanism controls the return speed to the extended position.



NOTE: RETURN SPEED GRAPHS ILLUSTRATE "SPEED CONTROLLED" PROFILES. PLEASE SPECIFY WHEN ORDERING

We reserve the right to add, delete or modify components without notification.
All dimensions are stated in mm.
All dimensions are nominal unless tolerance is stated.

GSNI Black Nitride Shaft Gas Spring, The Nitrider™ !

The **GSNI Black Nitride Shaft Gas Spring**. This gas spring the **Nitrider™**, combines all the proven reliability you've come to expect from an **SPD Gas Spring** along with the added feature of a nitride shaft. The **GSNI Gas Spring** incorporates a strong annealed steel rod with a Nitride coating for added corrosion resistance, especially when used with the **PS30B1** composite end fitting with nitrided clip. The **Nitrider™**, surpasses a 144 hour salt spray test! This gas spring is an ideal choice where exceptional quality, corrosion resistance and an overall black appearance are important to your application.

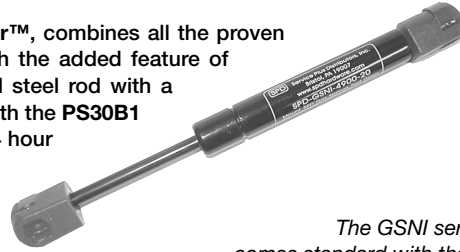

The GSNI series gas spring comes standard with the PS30B1 end fitting except for the GSNI-3100 series which come standard with the PS100 end fitting.

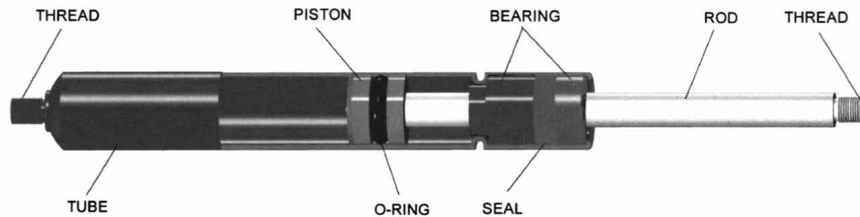

PART NUMBERS

Catalog Number	Rod Diameter (D)		Tube O.D.		Stroke (S)		"Base Cylinder Length (BL)"		Extended Length (L)		Force		End Fitting	Thread
	in	mm	in	mm	in	mm	in	mm	in	mm	lbs	N		
GSNI-4900-10	0.236	6.0	0.591	15.0	2.00	50	6.08	154	7.50	190	10	45	EF-PS30B1	M6 x 1.0
GSNI-4900-20											20	90	EF-PS30B1	M6 x 1.0
GSNI-4900-30											30	133	EF-PS30B1	M6 x 1.0
GSNI-4900-40											40	178	EF-PS30B1	M6 x 1.0
GSNI-4900-50											50	224	EF-PS30B1	M6 x 1.0
GSNI-4900-60											60	267	EF-PS30B1	M6 x 1.0
GSNI-4900-70											70	311	EF-PS30B1	M6 x 1.0
GSNI-4900-80											80	356	EF-PS30B1	M6 x 1.0
GSNI-2900-20	0.315	8.0	0.709	18.0	2.00	50	6.08	154	7.50	190	20	95	EF-PS30B1	M6 x 1.0
GSNI-2900-30											30	133	EF-PS30B1	M6 x 1.0
GSNI-2900-40											40	178	EF-PS30B1	M6 x 1.0
GSNI-2900-50											50	224	EF-PS30B1	M6 x 1.0
GSNI-2900-60											60	267	EF-PS30B1	M6 x 1.0
GSNI-2900-70											70	311	EF-PS30B1	M6 x 1.0
GSNI-2900-80											80	356	EF-PS30B1	M6 x 1.0
GSNI-2900-90											90	400	EF-PS30B1	M6 x 1.0
GSNI-2900-100											100	445	EF-PS30B1	M6 x 1.0
GSNI-2900-110											110	489	EF-PS30B1	M6 x 1.0
GSNI-2900-120											120	534	EF-PS30B1	M6 x 1.0
GSNI-4160-11	0.236	6.0	0.591	15.0	2.36	60	6.30	160	7.72	196	11.2	45	EF-PS30B1	M6 x 1.0
GSNI-4160-22											22.5	100	EF-PS30B1	M6 x 1.0
GSNI-4160-33											33.7	150	EF-PS30B1	M6 x 1.0
GSNI-4160-45											45.0	200	EF-PS30B1	M6 x 1.0
GSNI-4160-56											56.2	250	EF-PS30B1	M6 x 1.0
GSNI-4160-67											67.4	300	EF-PS30B1	M6 x 1.0
GSNI-4160-78											78.7	350	EF-PS30B1	M6 x 1.0
GSNI-4160-89											89.9	400	EF-PS30B1	M6 x 1.0

*Indicates New Metric Line
BOLD Indicates New Item
For force in Newtons (N), multiply pounds (lbs.) by 4.448.

Other end fittings are available. Please see pages 67 and 80-81 for instructions and complete details.
Other forces available upon request.

GSNI Black Nitride Shaft Gas Spring, The Nitrider™ !

Catalog Number	Rod Diameter (D)		Tube O.D.		Stroke (S)		"Base Cylinder Length (BL)"		Extended Length (L)		Force		End Fitting	Thread
	in	mm	in	mm	in	mm	in	mm	in	mm	lbs	N		
N08BAC0095	0.315	8.0	0.709	18.0	2.36	60	6.65	169			20	95	NONE	M6 x 1.0
N06VBN0150	0.236	6.0	0.591	15.0	2.87	73	7.21	183			34	150	NONE	M6 x 1.0
GANI-0615-0315-010	0.236	6.0	0.591	15.0	3.15	80	7.87	200	9.29	236	10	45	EF-PS30B1	M6 x 1.0
N08DAE0095	0.315	8.0	0.709	18.0	3.15	80	8.23	209			20	95	NONE	M6 x 1.0
GANI-0818-0315-085	0.315	8.0	0.709	18.0	3.35	80	8.23	209	9.63	245	85	380	EFPS91BP	M6 x 1.0
GSNI-5000-10	0.236	6.0	0.591	15.0	3.00	75	8.58	218	10.00	254	10	45	EF-PS30B1	M6 x 1.0
GSNI-5000-20											20	95	EF-PS30B1	M6 x 1.0
GSNI-5000-30											30	133	EF-PS30B1	M6 x 1.0
GSNI-5000-40											40	178	EF-PS30B1	M6 x 1.0
GSNI-5000-50											50	224	EF-PS30B1	M6 x 1.0
GSNI-5000-60											60	267	EF-PS30B1	M6 x 1.0
GSNI-5000-70											70	311	EF-PS30B1	M6 x 1.0
GSNI-5000-80											80	356	EF-PS30B1	M6 x 1.0
GSNI-2000-20	0.315	8.0	0.709	18.0	3.00	75	8.58	218	10.00	254	20	95	EF-PS30B1	M6 x 1.0
GSNI-2000-30											30	133	EF-PS30B1	M6 x 1.0
GSNI-2000-40											40	178	EF-PS30B1	M6 x 1.0
GSNI-2000-50											50	224	EF-PS30B1	M6 x 1.0
GSNI-2000-60											60	267	EF-PS30B1	M6 x 1.0
GSNI-2000-70											70	311	EF-PS30B1	M6 x 1.0
GSNI-2000-80											80	356	EF-PS30B1	M6 x 1.0
GSNI-2000-90											90	400	EF-PS30B1	M6 x 1.0
GSNI-2000-100											100	445	EF-PS30B1	M6 x 1.0
GSNI-2000-110											110	489	EF-PS30B1	M6 x 1.0
GSNI-2000-120											120	534	EF-PS30B1	M6 x 1.0
GSNI-2000-150											150	667	EF-PS30B1	M6 x 1.0
GSNI-2050-20	0.315	8.0	0.709	18.0	3.00	75	9.08	231	10.50	267	20	95	EF-PS30B1	M6 x 1.0
GSNI-2050-30											30	133	EF-PS30B1	M6 x 1.0
GSNI-2050-40											40	178	EF-PS30B1	M6 x 1.0
GSNI-2050-50											50	224	EF-PS30B1	M6 x 1.0
GSNI-2050-60											60	267	EF-PS30B1	M6 x 1.0
GSNI-2050-70											70	311	EF-PS30B1	M6 x 1.0
GSNI-2050-80											80	356	EF-PS30B1	M6 x 1.0
GSNI-2050-90											90	400	EF-PS30B1	M6 x 1.0
GSNI-2050-100											100	445	EF-PS30B1	M6 x 1.0
GSNI-2050-110											110	489	EF-PS30B1	M6 x 1.0
GSNI-2050-120											120	534	EF-PS30B1	M6 x 1.0
GSNI-4240-11											0.236	6.0	0.591	15.0
GSNI-4240-22	22.5	100	EF-PS30B1	M6 x 1.0										
GSNI-4240-33	33.7	150	EF-PS30B1	M6 x 1.0										
GSNI-4240-45	45.0	200	EF-PS30B1	M6 x 1.0										
GSNI-4240-56	56.2	250	EF-PS30B1	M6 x 1.0										
GSNI-4240-67	67.4	300	EF-PS30B1	M6 x 1.0										
GSNI-4240-78	78.7	350	EF-PS30B1	M6 x 1.0										
GSNI-4240-89	89.9	400	EF-PS30B1	M6 x 1.0										
GSNI-2249-22	0.315	8.0	0.709	18.0	3.94	100	9.80	249	11.22	285	22.5	100	EF-PS30B1	M6 x 1.0
GSNI-2249-33											33.7	150	EF-PS30B1	M6 x 1.0

*Indicates New Metric Line
BOLD Indicates New Item
 For force in Newtons (N), multiply pounds (lbs.) by 4.448.

Other end fittings are available. Please see pages 67 and 80-81 for instructions and complete details.
 Other forces available upon request.

GSNI Black Nitride Shaft Gas Spring, The Nitrider™ !

Catalog Number	Rod Diameter (D)		Tube O.D.		Stroke (S)		"Base Cylinder Length (BL)"		Extended Length (L)		Force		End Fitting	Thread
	in	mm	in	mm	in	mm	in	mm	in	mm	lbs	N		
GSNI-2249-56	0.315	8.0	0.709	18.0	3.94	100	9.80	249	11.22	285	56.2	250	EF-PS30B1	M6 x 1.0
GSNI-2249-89											89.9	400	EF-PS30B1	M6 x 1.0
GSNI-2249-118											118.0	525	EF-PS30B1	M6 x 1.0
GSNI-2249-146											146.0	650	EF-PS30B1	M6 x 1.0
GSNI-3249-22	0.394	10.0	0.866	22.0	3.94	100	9.80	249	12.16	309	22.5	95	EF-PS100BP	M8 x 1.25
GSNI-3249-33											33.7	150	EF-PS100BP	M8 x 1.25
GSNI-3249-56											56.2	250	EF-PS100BP	M8 x 1.25
GSNI-3249-101											101.0	450	EF-PS100BP	M8 x 1.25
GSNI-3249-157											157.4	700	EF-PS100BP	M8 x 1.25
GSNI-3249-202											202.3	900	EF-PS100BP	M8 x 1.25
GSNI-3249-270	270.0	1200	EF-PS100BP	M8 x 1.25										
GSNI-2100-20	0.315	8.0	0.709	18.0	3.50	89	10.48	264	11.90	300	20	95	EF-PS30B1	M6 x 1.0
GSNI-2100-30											30	133	EF-PS30B1	M6 x 1.0
GSNI-2100-40											40	178	EF-PS30B1	M6 x 1.0
GSNI-2100-50											50	224	EF-PS30B1	M6 x 1.0
GSNI-2100-60											60	267	EF-PS30B1	M6 x 1.0
GSNI-2100-70											70	311	EF-PS30B1	M6 x 1.0
GSNI-2100-80											80	356	EF-PS30B1	M6 x 1.0
GSNI-2100-90											90	400	EF-PS30B1	M6 x 1.0
GSNI-2100-100											100	445	EF-PS30B1	M6 x 1.0
GSNI-2100-110											110	489	EF-PS30B1	M6 x 1.0
GSNI-2100-120											120	534	EF-PS30B1	M6 x 1.0
GSNI-2100-150											150	667	EF-PS30B1	M6 x 1.0
GSNI-5100-10	0.236	6.0	0.591	15.0	3.50	89	10.58	269	12.00	305	10	45	EF-PS30B1	M6 x 1.0
GSNI-5100-20											20	95	EF-PS30B1	M6 x 1.0
GSNI-5100-30											30	133	EF-PS30B1	M6 x 1.0
GSNI-5100-40											40	178	EF-PS30B1	M6 x 1.0
GSNI-5100-50											50	224	EF-PS30B1	M6 x 1.0
GSNI-5100-60											60	267	EF-PS30B1	M6 x 1.0
GSNI-5100-90	0.315	8.0	0.709	18.0	3.50	89	10.58	269	12.00	305	90	400	EF-PS30B1	M6 x 1.0
GSNI-2112-20	0.315	8.0	0.709	18.0	4.00	102	10.78	274	12.20	310	20	95	EF-PS91BP	M6 x 1.0
N06GAM0045	0.236	6.0	0.591	15.0	4.72	120	11.02	280			10	45	NONE	M6 x 1.0
N08GAN0095	0.315	8.0	0.709	18.0	4.72	120	11.38	289			20	95	NONE	M6 x 1.0
N14FAK0200	0.551	14.0	1.102	28.0	3.94	100	10.47	266			45	200	NONE	M10 x 1.5
N08HAO0095	0.315	8.0	0.709	18.0	5.51	140	12.95	329			20	95	NONE	M6 x 1.0
GSNI-4340-11	0.236	6.0	0.591	15.0	6.00	153	13.39	340	14.80	376	11	45	EF-PS30B1	M6 x 1.0
GSNI-4340-22											22.5	100	EF-PS30B1	M6 x 1.0
GSNI-4340-33											33.7	150	EF-PS30B1	M6 x 1.0
GSNI-4340-45											45.0	200	EF-PS30B1	M6 x 1.0
GSNI-4340-56											56.2	250	EF-PS30B1	M6 x 1.0
GSNI-4340-67											67.4	300	EF-PS30B1	M6 x 1.0
GSNI-4340-78											78.7	350	EF-PS30B1	M6 x 1.0
GSNI-5150-10	0.236	6.0	0.591	15.0	6.00	153	13.58	345	15.00	380	10	45	EF-PS30B1	M6 x 1.0
GSNI-5150-20											20	95	EF-PS30B1	M6 x 1.0
GSNI-5150-30											30	133	EF-PS30B1	M6 x 1.0
GSNI-5150-40											40	178	EF-PS30B1	M6 x 1.0
GSNI-5150-50											50	224	EF-PS30B1	M6 x 1.0

*Indicates New Metric Line
BOLD Indicates New Item
 For force in Newtons (N), multiply pounds (lbs.) by 4.448.

Other end fittings are available. Please see pages 67 and 80-81 for instructions and complete details.
 Other forces available upon request.

GSNI Black Nitride Shaft Gas Spring, The Nitrider™ !

Catalog Number	Rod Diameter (D)		Tube O.D.		Stroke (S)		"Base Cylinder Length (BL)"		Extended Length (L)		Force		End Fitting	Thread
	in	mm	in	mm	in	mm	in	mm	in	mm	lbs	N		
GSNI-5150-60	0.236	6.0	0.591	15.0	6.00	153	13.58	345	15.00	380	60	267	EF-PS30B1	M6 x 1.0
GSNI-5150-80											80	356	EF-PS30B1	M6 x 1.0
GSNI-2125-20	0.315	8.0	0.709	18.0	6.00	153	13.58	345	15.00	380	20	95	EF-PS30B1	M6 x 1.0
GSNI-2125-30											30	133	EF-PS30B1	M6 x 1.0
GSNI-2125-40											40	178	EF-PS30B1	M6 x 1.0
GSNI-2125-50											50	224	EF-PS30B1	M6 x 1.0
GSNI-2125-60											60	267	EF-PS30B1	M6 x 1.0
GSNI-2125-70											70	311	EF-PS30B1	M6 x 1.0
GSNI-2125-80											80	356	EF-PS30B1	M6 x 1.0
GSNI-2125-90											90	400	EF-PS30B1	M6 x 1.0
GSNI-2125-100											100	445	EF-PS30B1	M6 x 1.0
GSNI-2125-110											110	489	EF-PS30B1	M6 x 1.0
GSNI-2125-120											120	534	EF-PS30B1	M6 x 1.0
GSNI-2349-22											0.315	8.0	0.709	18.0
GSNI-2349-33	33.7	150	EF-PS30B1	M6 x 1.0										
GSNI-2349-56	56.2	250	EF-PS30B1	M6 x 1.0										
GSNI-2349-89	89.9	400	EF-PS30B1	M6 x 1.0										
GSNI-2349-118	118	525	EF-PS30B1	M6 x 1.0										
GSNI-2349-146	146	650	EF-PS30B1	M6 x 1.0										
GSNI-2150-20	0.315	8.0	0.709	18.0	6.00	153	13.83	351	15.25	385	20	95	EF-PS30B1	M6 x 1.0
GSNI-2150-30											30	133	EF-PS30B1	M6 x 1.0
GSNI-2150-60											60	267	EF-PS30B1	M6 x 1.0
GSNI-2150-90											90	400	EF-PS30B1	M6 x 1.0
GSNI-2150-120											120	534	EF-PS30B1	M6 x 1.0
GSNI-2150-150											150	667	EF-PS30B1	M6 x 1.0
GANI-0818-0630-020	0.315	8.0	0.709	18.0	6.30	160	14.53	369	15.95	405	20	95	EF-PS30B1	M6 x 1.0
N10JAR0095	0.394	10.0	0.866	22.0	5.91	150	13.74	349			21	95	NONE	M8 x 1.25
GSNI-5200-10	0.236	6.0	0.591	15.0	7.00	178	15.58	396	17.00	432	10	45	EF-PS30B1	M6 x 1.0
GSNI-5200-20											20	95	EF-PS30B1	M6 x 1.0
GSNI-5200-30											30	133	EF-PS30B1	M6 x 1.0
GSNI-5200-40											40	178	EF-PS30B1	M6 x 1.0
GSNI-5200-50											50	224	EF-PS30B1	M6 x 1.0
GSNI-5200-60											60	267	EF-PS30B1	M6 x 1.0
GSNI-5200-75											75	334	EF-PS30B1	M6 x 1.0
GSNI-2200-20											0.315	8.0	0.709	18.0
GSNI-2200-30	30	133	EF-PS30B1	M6 x 1.0										
GSNI-2200-40	40	178	EF-PS30B1	M6 x 1.0										
GSNI-2200-50	50	224	EF-PS30B1	M6 x 1.0										
GSNI-2200-60	60	267	EF-PS30B1	M6 x 1.0										
GSNI-2200-70	70	311	EF-PS30B1	M6 x 1.0										
GSNI-2200-80	80	356	EF-PS30B1	M6 x 1.0										
GSNI-2200-90	90	400	EF-PS30B1	M6 x 1.0										
GSNI-2200-100	100	445	EF-PS30B1	M6 x 1.0										
GSNI-2200-110	110	489	EF-PS30B1	M6 x 1.0										
GSNI-2200-120	120	534	EF-PS30B1	M6 x 1.0										
GSNI-2200-150	150	667	EF-PS30B1	M6 x 1.0										
N14JAS0200	0.551	14.0	1.102	28.0	5.91	150	14.41	366			45	200	NONE	M10 x 1.5

*Indicates New Metric Line
BOLD Indicates New Item
 For force in Newtons (N), multiply pounds (lbs.) by 4.448.

Other end fittings are available. Please see pages 67 and 80-81 for instructions and complete details.
 Other forces available upon request.

GSNI Black Nitride Shaft Gas Spring, The Nitrider™ !

Catalog Number	Rod Diameter (D)		Tube O.D.		Stroke (S)		"Base Cylinder Length (BL)"		Extended Length (L)		Force		End Fitting	Thread
	in	mm	in	mm	in	mm	in	mm	in	mm	lbs	N		
N08MAV0095	0.315	8.0	0.709	18.0	7.09	180	16.10	409			20	95	NONE	M6 x 1.0
GSNI-5250-10	0.236	6.0	0.591	15.0	7.50	197	17.08	434	18.50	470	10	45	EF-PS30B1	M6 x 1.0
GSNI-5250-20											20	95	EF-PS30B1	M6 x 1.0
GSNI-5250-30											30	133	EF-PS30B1	M6 x 1.0
GSNI-5250-45											45	200	EF-PS30B1	M6 x 1.0
GSNI-5250-60											60	267	EF-PS30B1	M6 x 1.0
GSNI-5250-75											75	334	EF-PS30B1	M6 x 1.0
GSNI-2250-90	0.315	8.0	0.709	18.0	7.50	197	17.08	434	18.50	470	90	400	EF-PS30B1	M6 x 1.0
GSNI-2250-120											120	534	EF-PS30B1	M6 x 1.0
GSNI-2250-150											150	667	EF-PS30B1	M6 x 1.0
GSNI-4440-11	0.236	6.0	0.591	15.0	7.87	200	17.32	440	18.74	476	10	50	EF-PS30B1	M6 x 1.0
GSNI-4440-22											22.5	100	EF-PS30B1	M6 x 1.0
GSNI-4440-33											33.7	150	EF-PS30B1	M6 x 1.0
GSNI-4440-56											56.2	250	EF-PS30B1	M6 x 1.0
GSNI-4440-89											89.9	400	EF-PS30B1	M6 x 1.0
GSNI-2449-22	0.315	8.0	0.709	18.0	7.87	200	17.68	449	19.10	485	22.5	95	EF-PS30B1	M6 x 1.0
GSNI-2449-33											33.7	150	EF-PS30B1	M6 x 1.0
GSNI-2449-56											56.2	250	EF-PS30B1	M6 x 1.0
GSNI-2449-89											89.9	400	EF-PS30B1	M6 x 1.0
GSNI-2449-118											118.0	525	EF-PS30B1	M6 x 1.0
GSNI-2449-135											135.0	650	EF-PS30B1	M6 x 1.0
GSNI-1466-45	0.551	14.0	1.102	28.0	7.87	200	18.35	466	21.11	536	45.0	200	EF-PS140BP	M10 x 1.5
GSNI-1466-112											112.4	500	EF-PS140BP	M10 x 1.5
GSNI-1466-179											179.9	800	EF-PS140BP	M10 x 1.5
GSNI-1466-269											269.8	1200	EF-PS140BP	M10 x 1.5
GSNI-1466-359											359.7	1600	EF-PS140BP	M10 x 1.5
GSNI-1466-449											449.6	2000	EF-PS140BP	M10 x 1.5
GSNI-1466-562											562.1	2500	EF-PS140BP	M10 x 1.5
GSNI-5300-10	0.236	6.0	0.591	15.0	8.00	203	18.58	469	20.00	508	10	45	EF-PS30B1	M6 x 1.0
GSNI-5300-20											20	95	EF-PS30B1	M6 x 1.0
GSNI-5300-30											30	133	EF-PS30B1	M6 x 1.0
GSNI-5300-40											40	178	EF-PS30B1	M6 x 1.0
GSNI-5300-50											50	224	EF-PS30B1	M6 x 1.0
GSNI-5300-60											60	267	EF-PS30B1	M6 x 1.0
GSNI-2300-20	0.315	8.0	0.709	18.0	8.00	203	18.58	469	20.00	508	20	95	EF-PS30B1	M6 x 1.0
GSNI-2300-30											30	133	EF-PS30B1	M6 x 1.0
GSNI-2300-40											40	178	EF-PS30B1	M6 x 1.0
GSNI-2300-50											50	224	EF-PS30B1	M6 x 1.0
GSNI-2300-60											60	267	EF-PS30B1	M6 x 1.0
GSNI-2300-70											70	311	EF-PS30B1	M6 x 1.0
GSNI-2300-75											75	334	EF-PS30B1	M6 x 1.0
GSNI-2300-80											80	356	EF-PS30B1	M6 x 1.0
GSNI-2300-90											90	400	EF-PS30B1	M6 x 1.0
GSNI-2300-100											100	445	EF-PS30B1	M6 x 1.0
GSNI-2300-110											110	489	EF-PS30B1	M6 x 1.0
GSNI-2300-120											120	534	EF-PS30B1	M6 x 1.0

*Indicates New Metric Line
BOLD Indicates New Item
 For force in Newtons (N), multiply pounds (lbs.) by 4.448.

Other end fittings are available. Please see pages 67 and 80-81 for instructions and complete details.
 Other forces available upon request.

GSNI Black Nitride Shaft Gas Spring, The Nitrider™ !

Catalog Number	Rod Diameter (D)		Tube O.D.		Stroke (S)		"Base Cylinder Length (BL)"		Extended Length (L)		Force		End Fitting	Thread
	in	mm	in	mm	in	mm	in	mm	in	mm	lbs	N		
GSNI-2300-130	0.315	8.0	0.709	18.0	8.00	203	18.58	469	20.00	508	130	578	EF-PS30B1	M6 x 1.0
GSNI-2300-150											150	667	EF-PS30B1	M6 x 1.0
GSNI-3020-20	0.394	10.0	0.866	22.0	7.87	200	17.84	453	20.20	513	21	95	EF-PS100BP	M8 x 1.25
GSNI-3020-30											30	133	EF-PS100BP	M8 x 1.25
GSNI-3020-40											40	178	EF-PS100BP	M8 x 1.25
GSNI-3020-50											50	224	EF-PS100BP	M8 x 1.25
GSNI-3020-60											60	267	EF-PS100BP	M8 x 1.25
GSNI-3020-70											70	311	EF-PS100BP	M8 x 1.25
GSNI-3020-80											80	356	EF-PS100BP	M8 x 1.25
GSNI-3020-90											90	400	EF-PS100BP	M8 x 1.25
GSNI-3020-100											100	445	EF-PS100BP	M8 x 1.25
GSNI-3020-110											110	489	EF-PS100BP	M8 x 1.25
GSNI-3020-120											120	534	EF-PS100BP	M8 x 1.25
GSNI-3020-130											130	578	EF-PS100BP	M8 x 1.25
GSNI-3020-140											140	623	EF-PS100BP	M8 x 1.25
GSNI-3020-150											150	667	EF-PS100BP	M8 x 1.25
GSNI-3020-160											160	712	EF-PS100BP	M8 x 1.25
GSNI-3020-170											170	756	EF-PS100BP	M8 x 1.25
GSNI-3020-180											180	801	EF-PS100BP	M8 x 1.25
N08OBB0095											0.315	8.0	0.709	18.0
GSNI-2400-20	0.315	8.0	0.709	18.0	9.84	250	21.61	549	23.03	585	20	95	EF-PS30B1	M6 x 1.0
GSNI-2400-30											30	133	EF-PS30B1	M6 x 1.0
GSNI-2400-40											40	178	EF-PS30B1	M6 x 1.0
GSNI-2400-50											50	224	EF-PS30B1	M6 x 1.0
GSNI-2400-60											60	267	EF-PS30B1	M6 x 1.0
GSNI-2400-70											70	311	EF-PS30B1	M6 x 1.0
GSNI-2400-80											80	356	EF-PS30B1	M6 x 1.0
GSNI-2400-90											90	400	EF-PS30B1	M6 x 1.0
GSNI-2400-100											100	445	EF-PS30B1	M6 x 1.0
GSNI-2400-110											110	489	EF-PS30B1	M6 x 1.0
GSNI-2400-120											120	534	EF-PS30B1	M6 x 1.0
GSNI-3549-22											0.394	10.0	0.866	22.0
GSNI-3549-33	33.7	150	EF-PS100BP	M8 x 1.25										
GSNI-3549-56	56.2	250	EF-PS100BP	M8 x 1.25										
GSNI-3549-101	101.2	450	EF-PS100BP	M8 x 1.25										
GSNI-3549-157	157.4	700	EF-PS100BP	M8 x 1.25										
GSNI-3549-202	202.3	900	EF-PS100BP	M8 x 1.25										
GSNI-3549-269	269.8	1200	EF-PS100BP	M8 x 1.25										
N14PBD0200	0.551	14.0	1.102	28.0	9.84	250	22.28	566						
GSNI-2600-20	0.315	8.0	0.709	18.0	11.00	279	24.88	632	26.30	668	20	95	EF-PS90M1BP	M6 x 1.0
GSNI-2600-30											30	133	EF-PS90M1BP	M6 x 1.0
GSNI-2600-40											40	178	EF-PS90M1BP	M6 x 1.0
GSNI-2600-50											50	224	EF-PS90M1BP	M6 x 1.0
GSNI-2600-60											60	267	EF-PS90M1BP	M6 x 1.0
GSNI-2600-70											70	311	EF-PS90M1BP	M6 x 1.0
GSNI-2600-80											80	356	EF-PS90M1BP	M6 x 1.0
GSNI-2600-90											90	400	EF-PS90M1BP	M6 x 1.0

*Indicates New Metric Line
BOLD Indicates New Item
 For force in Newtons (N), multiply pounds (lbs.) by 4.448.

Other end fittings are available. Please see pages 67 and 80-81 for instructions and complete details.
 Other forces available upon request.

GSNI Black Nitride Shaft Gas Spring, The Nitrider™ !

Catalog Number	Rod Diameter (D)		Tube O.D.		Stroke (S)		"Base Cylinder Length (BL)"		Extended Length (L)		Force		End Fitting	Thread
	in	mm	in	mm	in	mm	in	mm	in	mm	lbs	N		
GSNI-2600-100	0.315	8.0	0.709	18.0	11.00	279	24.88	632	26.30	668	100	445	EF-PS90M1BP	M6 x 1.0
GSNI-2600-110											110	489	EF-PS90M1BP	M6 x 1.0
GSNI-2600-120											120	534	EF-PS90M1BP	M6 x 1.0
GSNI-2600-150											150	667	EF-PS90M1BP	M6 x 1.0
GSNI-3000-30	0.394	10.0	0.866	22.0	11.00	279	24.88	632	26.30	668	30	133	EF-PS30B1	M6 x 1.0
GSNI-3000-40											40	178	EF-PS30B1	M6 x 1.0
GSNI-3000-50											50	224	EF-PS30B1	M6 x 1.0
GSNI-3000-60											60	267	EF-PS30B1	M6 x 1.0
GSNI-3000-70											70	311	EF-PS30B1	M6 x 1.0
GSNI-3000-80											80	356	EF-PS30B1	M6 x 1.0
GSNI-3000-90											90	400	EF-PS30B1	M6 x 1.0
GSNI-3000-100											100	445	EF-PS30B1	M6 x 1.0
GSNI-3000-110											110	489	EF-PS30B1	M6 x 1.0
GSNI-3000-120											120	534	EF-PS30B1	M6 x 1.0
GSNI-3000-130											130	578	EF-PS30B1	M6 x 1.0
GSNI-3000-140											140	623	EF-PS30B1	M6 x 1.0
GSNI-3000-150											150	667	EF-PS30B1	M6 x 1.0
GSNI-3000-160											160	712	EF-PS30B1	M6 x 1.0
GSNI-3000-170											170	756	EF-PS30B1	M6 x 1.0
GSNI-3000-180											180	801	EF-PS30B1	M6 x 1.0
GSNI-3050-20	0.394	10.0	0.866	22.0	11.81	300	25.55	649	26.97	685	21	95	EF-PS30B1	M6 x 1.0
GSNI-3050-30											30	133	EF-PS30B1	M6 x 1.0
GSNI-3050-40											40	178	EF-PS30B1	M6 x 1.0
GSNI-3050-50											50	224	EF-PS30B1	M6 x 1.0
GSNI-3050-60											60	267	EF-PS30B1	M6 x 1.0
GSNI-3050-70											70	311	EF-PS30B1	M6 x 1.0
GSNI-3050-80											80	356	EF-PS30B1	M6 x 1.0
GSNI-3050-90											90	400	EF-PS30B1	M6 x 1.0
GSNI-3050-100											100	445	EF-PS30B1	M6 x 1.0
GSNI-3050-110											110	489	EF-PS30B1	M6 x 1.0
GSNI-3050-120											120	534	EF-PS30B1	M6 x 1.0
GSNI-3050-130											130	578	EF-PS30B1	M6 x 1.0
GSNI-3050-140											140	623	EF-PS30B1	M6 x 1.0
GSNI-3050-150											150	667	EF-PS30B1	M6 x 1.0
GSNI-3050-160											160	712	EF-PS30B1	M6 x 1.0
GSNI-3050-170											170	756	EF-PS30B1	M6 x 1.0
GSNI-3050-180	180	801	EF-PS30B1	M6 x 1.0										
GSNI-1666-45	0.551	14.0	1.102	28.0	11.81	300	26.22	666	28.96	735	45	200	EF-PS140BP	M10 x 1.5
GSNI-1666-111											111.6	500	EF-PS140BP	M10 x 1.5
GSNI-1666-179											179.9	800	EF-PS140BP	M10 x 1.5
GSNI-1666-269											269.8	1200	EF-PS140BP	M10 x 1.5
GSNI-1666-359											359.7	1600	EF-PS140BP	M10 x 1.5
GSNI-1666-449											449.6	2000	EF-PS140BP	M10 x 1.5
GSNI-1666-562	562.1	2500	EF-PS140BP	M10 x 1.5										
GSNI-2800-20	0.315	8.0	0.709	18.0	11.50	292	26.58	675	28.00	711	20	95	EF-PS30B1	M6 x 1.0
GSNI-2800-30											30	133	EF-PS30B1	M6 x 1.0

*Indicates New Metric Line
BOLD Indicates New Item
 For force in Newtons (N), multiply pounds (lbs.) by 4.448.

Other end fittings are available. Please see pages 67 and 80-81 for instructions and complete details.
 Other forces available upon request.

GSNI Black Nitride Shaft Gas Spring, The Nitrider™ !

Catalog Number	Rod Diameter (D)		Tube O.D.		Stroke (S)		"Base Cylinder Length (BL)"		Extended Length (L)		Force		End Fitting	Thread										
	in	mm	in	mm	in	mm	in	mm	in	mm	lbs	N												
GSNI-2800-40	0.315	8.0	0.709	18.0	11.50	292	26.58	666	28.96	735	40	178	EF-PS30B1	M6 x 1.0										
GSNI-2800-50											50	224	EF-PS30B1	M6 x 1.0										
GSNI-2800-60											60	267	EF-PS30B1	M6 x 1.0										
GSNI-2800-70											70	311	EF-PS30B1	M6 x 1.0										
GSNI-2800-80											80	356	EF-PS30B1	M6 x 1.0										
GSNI-2800-90											90	400	EF-PS30B1	M6 x 1.0										
GSNI-2800-100											100	445	EF-PS30B1	M6 x 1.0										
GSNI-2800-110											110	489	EF-PS30B1	M6 x 1.0										
GSNI-2800-120											120	534	EF-PS30B1	M6 x 1.0										
GSNI-2800-130											130	578	EF-PS30B1	M6 x 1.0										
GSNI-2800-140											140	623	EF-PS30B1	M6 x 1.0										
GSNI-2800-150											150	667	EF-PS30B1	M6 x 1.0										
GSNI-3100-20											0.394	10.0	0.866	22.0	11.50	292.0	25.64	650	28.00	711	20	95	EF-PS100BP	M8 x 1.25
GSNI-3100-30																					30	133	EF-PS100BP	M8 x 1.25
GSNI-3100-40																					40	178	EF-PS100BP	M8 x 1.25
GSNI-3100-50	50	224	EF-PS100BP	M8 x 1.25																				
GSNI-3100-60	60	267	EF-PS100BP	M8 x 1.25																				
GSNI-3100-70	70	311	EF-PS100BP	M8 x 1.25																				
GSNI-3100-80	80	356	EF-PS100BP	M8 x 1.25																				
GSNI-3100-90	90	400	EF-PS100BP	M8 x 1.25																				
GSNI-3100-100	100	445	EF-PS100BP	M8 x 1.25																				
GSNI-3100-110	110	489	EF-PS100BP	M8 x 1.25																				
GSNI-3100-120	120	534	EF-PS100BP	M8 x 1.25																				
GSNI-3100-130	130	578	EF-PS100BP	M8 x 1.25																				
GSNI-3100-140	140	623	EF-PS100BP	M8 x 1.25																				
GSNI-3100-150	150	667	EF-PS100BP	M8 x 1.25																				
GSNI-3100-160	160	712	EF-PS100BP	M8 x 1.25																				
GSNI-3100-170	170	756	EF-PS100BP	M8 x 1.25																				
GSNI-3100-175	175	778	EF-PS100BP	M8 x 1.25																				
GSNI-3100-180	180	801	EF-PS100BP	M8 x 1.25																				
GSNI-3100-200	200	890	EF-PS100BP	M8 x 1.25																				
GSNI-3100-250	250	1112	EF-PS100BP	M8 x 1.25																				
GSNI-3200-20	0.394	10.0	0.866	22.0	13.78	350	29.49	749	30.91	785	22	95	EF-PS30B1	M6 x 1.0										
GSNI-3200-30											30	133	EF-PS30B1	M6 x 1.0										
GSNI-3200-40											40	178	EF-PS30B1	M6 x 1.0										
GSNI-3200-50											50	224	EF-PS30B1	M6 x 1.0										
GSNI-3200-60											60	267	EF-PS30B1	M6 x 1.0										
GSNI-3200-70											70	311	EF-PS30B1	M6 x 1.0										
GSNI-3200-80											80	356	EF-PS30B1	M6 x 1.0										
GSNI-3200-90											90	400	EF-PS30B1	M6 x 1.0										
GSNI-3200-100											100	445	EF-PS30B1	M6 x 1.0										
GSNI-3200-110											110	489	EF-PS30B1	M6 x 1.0										
GSNI-3200-120											120	534	EF-PS30B1	M6 x 1.0										
GSNI-3200-130											130	578	EF-PS30B1	M6 x 1.0										
GSNI-3200-140											140	623	EF-PS30B1	M6 x 1.0										
GSNI-3200-150											150	667	EF-PS30B1	M6 x 1.0										
GSNI-3200-160											160	712	EF-PS30B1	M6 x 1.0										

*Indicates New Metric Line
BOLD Indicates New Item
 For force in Newtons (N), multiply pounds (lbs.) by 4.448.

Other end fittings are available. Please see pages 67 and 80-81 for instructions and complete details.
 Other forces available upon request.

GSNI Black Nitride Shaft Gas Spring, The Nitrider™ !

Catalog Number	Rod Diameter (D)		Tube O.D.		Stroke (S)		"Base Cylinder Length (BL)"		Extended Length (L)		Force		End Fitting	Thread										
	in	mm	in	mm	in	mm	in	mm	in	mm	lbs	N												
GSNI-3200-170	0.394	10.0	0.866	22.0	13.78	350	29.49	749	30.91	785	170	756	EF-PS30B1	M6 x 1.0										
GSNI-3200-180											180	801	EF-PS30B1	M6 x 1.0										
N14SBJ0200	0.551	14.0	1.102	28.0	13.78	350	30.16	766			45	200	NONE	M10 x 1.5										
GSNI-3849-22	0.394	10.0	0.866	22.0	15.75	400	33.43	849	35.79	910	22	95	EF-PS100BP	M8 x 1.25										
GSNI-3849-33											33.7	150	EF-PS100BP	M8 x 1.25										
GSNI-3849-56											56.2	250	EF-PS100BP	M8 x 1.25										
GSNI-3849-101											101.2	450	EF-PS100BP	M8 x 1.25										
GSNI-3849-157											157.4	700	EF-PS100BP	M8 x 1.25										
GSNI-3849-202											202.3	900	EF-PS100BP	M8 x 1.25										
GSNI-3849-269											269.8	1200	EF-PS100BP	M8 x 1.25										
GSNI-3610-30											0.394	10.0	0.866	22.0	15.2	386	34.88	886	36.3	668	30	133	EF-PS90M1BP	M6 x 1.0
GSNI-3610-40	40	178	EF-PS90M1BP	M6 x 1.0																				
GSNI-3610-50	50	224	EF-PS90M1BP	M6 x 1.0																				
GSNI-3610-60	60	267	EF-PS90M1BP	M6 x 1.0																				
GSNI-3610-70	70	311	EF-PS90M1BP	M6 x 1.0																				
GSNI-3610-80	80	356	EF-PS90M1BP	M6 x 1.0																				
GSNI-3610-90	90	400	EF-PS90M1BP	M6 x 1.0																				
GSNI-3610-100	100	445	EF-PS90M1BP	M6 x 1.0																				
GSNI-3610-110	110	489	EF-PS90M1BP	M6 x 1.0																				
GSNI-3610-120	120	534	EF-PS90M1BP	M6 x 1.0																				
GSNI-3610-130	130	578	EF-PS90M1BP	M6 x 1.0																				
GSNI-3610-140	140	623	EF-PS90M1BP	M6 x 1.0																				
GSNI-3610-150	150	667	EF-PS90M1BP	M6 x 1.0																				
GSNI-3610-160	160	712	EF-PS90M1BP	M6 x 1.0																				
GSNI-3610-170	170	756	EF-PS90M1BP	M6 x 1.0																				
GSNI-3610-180	180	801	EF-PS90M1BP	M6 x 1.0																				
GSNI-3600-30	0.394	10.0	0.866	22.0	15.2	386	33.94	862	36.3	668											30	133	EF-PS100BP	M8 x 1.25
GSNI-3600-40																					40	178	EF-PS100BP	M8 x 1.25
GSNI-3600-50											50	224	EF-PS100BP	M8 x 1.25										
GSNI-3600-60											60	267	EF-PS100BP	M8 x 1.25										
GSNI-3600-70											70	311	EF-PS100BP	M8 x 1.25										
GSNI-3600-80											80	356	EF-PS100BP	M8 x 1.25										
GSNI-3600-90											90	400	EF-PS100BP	M8 x 1.25										
GSNI-3600-100											100	445	EF-PS100BP	M8 x 1.25										
GSNI-3600-110											110	489	EF-PS100BP	M8 x 1.25										
GSNI-3600-120											120	534	EF-PS100BP	M8 x 1.25										
GSNI-3600-130											130	578	EF-PS100BP	M8 x 1.25										
GSNI-3600-140											140	623	EF-PS100BP	M8 x 1.25										
GSNI-3600-150											150	667	EF-PS100BP	M8 x 1.25										
GSNI-3600-160											160	712	EF-PS100BP	M8 x 1.25										
GSNI-3600-170											170	756	EF-PS100BP	M8 x 1.25										
GSNI-3600-180											180	801	EF-PS100BP	M8 x 1.25										
GSNI-1866-45											0.551	14.0	1.102	28.0	15.75	400	34.88	866	37.64	956	45	200	EF-PS140BP	M10 x 1.5
GSNI-1866-112																					112.4	500	EF-PS140BP	M10 x 1.5
GSNI-1866-179	179.9	800	EF-PS140BP	M10 x 1.5																				
GSNI-1866-269	269.8	1200	EF-PS140BP	M10 x 1.5																				

*Indicates New Metric Line
BOLD Indicates New Item
For force in Newtons (N), multiply pounds (lbs.) by 4.448.

Other end fittings are available. Please see pages 67 and 80-81 for instructions and complete details.
Other forces available upon request.

GSNI Black Nitride Shaft Gas Spring, The Nitrider™ !

Catalog Number	Rod Diameter (D)		Tube O.D.		Stroke (S)		"Base Cylinder Length (BL)"		Extended Length (L)		Force		End Fitting	Thread
	in	mm	in	mm	in	mm	in	mm	in	mm	lbs	N		
GSNI-1866-359	0.551	14.0	1.102	28.0	15.75	400	34.88	866	37.64	956	359.7	1600	EF-PS140BP	M10 x 1.5
GSNI-1866-449											449.6	2000		
GSNI-1866-562											562.1	2500		
GSNI-1066-45	0.551	14.0	1.102	28.0	19.69	500	41.97	1066	44.73	1136	45	200	EF-PS140BP	M10 x 1.5
GSNI-1066-112											112.4	500		
GSNI-1066-179											179.9	800		
GSNI-1066-269											269.8	1200		
GSNI-1066-359											359.7	1600		
GSNI-1066-449											449.6	2000		
GSNI-1066-562											562.1	2500		

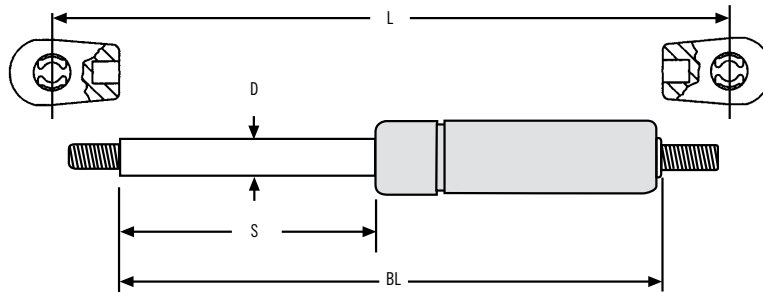

GSMT Multi-Range Gas Spring, The Multi Stop™!

The **GSMT Multi-Range Gas Spring**. This gas spring the **Multi Stop™** operates much like the standard Nitrider™ in that it allows a lid or door to open to 90° and lock internally. By applying an additional opening force the gas spring “breaks away” and continues to extend to the desired fully opening angle (typically 170°- 180°). The gas spring will work the same way when compressing or closing the lid. Grooves in the tube allow the **Multi Stop™** gas spring to stop at various angles depending on how many grooves are on the tube.

The **GSMT Multi Stop™** is a special order item only and can be custom designed to fit your particular application. SPD can design the gas spring to your desired length, stroke, force and number of stops by varying the number of grooves formed into the tube.

The **GSMT Multi Stop™** gas spring is an excellent choice for RV luggage door on pop-outs. Allow our engineering staff to assist you in designing the **Multi Stop™** into your design.

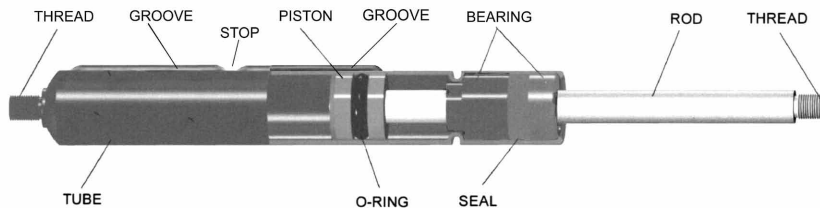
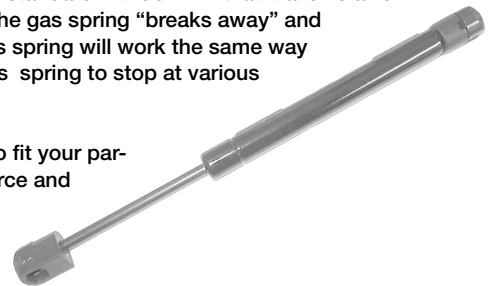



GSSX Stainless Steel gas springs! These gas springs are made of corrosion resistant **316 Stainless Steel** which make them an ideal choice wherever harsh conditions or environment are a concern. All stainless steel parts also have a specially prepared surface to give additional hardness and corrosion resistance. Add our exclusive all composite PS130 end fitting and you will have a gas spring that will not rust or corrode even in marine environments.

The **GSSX Gas Springs** are an excellent choice for all marine applications as well as medical or food service applications where a high degree of cleanliness is a must.

PART NUMBERS

Catalog Number	Rod Diameter (D)		Tube O.D.		Stroke (S)		Base Length (BL) Cylinder		Extended Length (L)		Force		End Fitting	Thread
	in	mm	in	mm	in	mm	in	mm	in	mm	lbs	N		
GSSX-4900-10	0.236	6.0	0.591	15.0	2.00	50	6.08	154	7.50	190	10	45	EF-PS130	M6 x 1.0
GSSX-4900-20											20	90	EF-PS130	M6 x 1.0
GSSX-4900-30											30	133	EF-PS130	M6 x 1.0
GSSX-4900-40											40	178	EF-PS130	M6 x 1.0
GSSX-4900-50											50	224	EF-PS130	M6 x 1.0
GSSX-4900-60											60	267	EF-PS130	M6 x 1.0
GSSX-4900-70											70	311	EF-PS130	M6 x 1.0
GSSX-4900-80											80	356	EF-PS130	M6 x 1.0
GSSX-2900-20	0.315	8.0	0.709	18.0	2.00	50	6.08	154	7.50	190	20	95	EF-PS130	M6 x 1.0
GSSX-2900-30											30	133	EF-PS130	M6 x 1.0
GSSX-2900-40											40	178	EF-PS130	M6 x 1.0
GSSX-2900-50											50	224	EF-PS130	M6 x 1.0
GSSX-2900-60											60	267	EF-PS130	M6 x 1.0
GSSX-2900-70											70	311	EF-PS130	M6 x 1.0
GSSX-2900-80											80	356	EF-PS130	M6 x 1.0
GSSX-2900-90											90	400	EF-PS130	M6 x 1.0
GSSX-2900-100											100	445	EF-PS130	M6 x 1.0
GSSX-2900-110											110	489	EF-PS130	M6 x 1.0
GSSX-2900-120	120	534	EF-PS130	M6 x 1.0										
GSSX-4160-11	0.236	6.0	0.591	15.0	2.36	60	6.30	160	7.72	196	11.2	45	EF-PS130	M6 x 1.0
GSSX-4160-22											22.5	100	EF-PS130	M6 x 1.0
GSSX-4160-33											33.7	150	EF-PS130	M6 x 1.0
GSSX-4160-45											45.0	200	EF-PS130	M6 x 1.0
GSSX-4160-56											56.2	250	EF-PS130	M6 x 1.0
GSSX-4160-67											67.4	300	EF-PS130	M6 x 1.0
GSSX-4160-78											78.7	350	EF-PS130	M6 x 1.0
GSSX-4160-89											89.9	400	EF-PS130	M6 x 1.0
S08BAC0095	0.315	8.0	0.709	18.0	2.36	60	6.65	169			20	95	NONE	M6 x 1.0
S06DAD0045	0.236	6.0	0.591	15.0	3.15	80	7.87	200			10	45	NONE	M6 x 1.0
S08DAE0095	0.315	8.0	0.709	18.0	3.15	80	8.23	209			20	95	NONE	M6 x 1.0
GSSX-5000-10	0.236	6.0	0.591	15.0	3.00	75	8.58	218	10.00	254	10	45	EF-PS130	M6 x 1.0
GSSX-5000-20											20	95	EF-PS130	M6 x 1.0
GSSX-5000-30											30	133	EF-PS130	M6 x 1.0
GSSX-5000-40											40	178	EF-PS130	M6 x 1.0
GSSX-5000-50											50	224	EF-PS130	M6 x 1.0
GSSX-5000-60											60	267	EF-PS130	M6 x 1.0
GSSX-5000-70											70	311	EF-PS130	M6 x 1.0
GSSX-5000-80											80	356	EF-PS130	M6 x 1.0

*Indicates New Metric Line
BOLD Indicates New Item
 For force in Newtons (N), multiply pounds (lbs.) by 4.448.

Other end fittings are available. Please see pages 67 and 80-81 for instructions and complete details.
 Other forces available upon request.

GSSX Stainless Steel Gas Springs

Catalog Number	Rod Diameter (D)		Tube O.D.		Stroke (S)		Base Length (BL) Cylinder		Extended Length (L)		Force		End Fitting	Thread										
GSSX-2000-20	0.315	8.0	0.709	18.0	3.00	75	8.58	218	10.00	254	20	95	EF-PS130	M6 x 1.0										
GSSX-2000-30											30	133	EF-PS130	M6 x 1.0										
GSSX-2000-40											40	178	EF-PS130	M6 x 1.0										
GSSX-2000-50											50	224	EF-PS130	M6 x 1.0										
GSSX-2000-60											60	267	EF-PS130	M6 x 1.0										
GSSX-2000-70											70	311	EF-PS130	M6 x 1.0										
GSSX-2000-80											80	356	EF-PS130	M6 x 1.0										
GSSX-2000-90											90	400	EF-PS130	M6 x 1.0										
GSSX-2000-100											100	445	EF-PS130	M6 x 1.0										
GSSX-2000-110											110	489	EF-PS130	M6 x 1.0										
GSSX-2000-120											120	534	EF-PS130	M6 x 1.0										
GSSX-2000-150											150	667	EF-PS130	M6 x 1.0										
GSSX-2050-20											0.315	8.0	0.709	18.0	3.00	75	9.08	231	10.50	267	20	95	EF-PS130	M6 x 1.0
GSSX-2050-30																					30	133	EF-PS130	M6 x 1.0
GSSX-2050-40	40	178	EF-PS130	M6 x 1.0																				
GSSX-2050-50	50	224	EF-PS130	M6 x 1.0																				
GSSX-2050-60	60	267	EF-PS130	M6 x 1.0																				
GSSX-2050-70	70	311	EF-PS130	M6 x 1.0																				
GSSX-2050-80	80	356	EF-PS130	M6 x 1.0																				
GSSX-2050-90	90	400	EF-PS130	M6 x 1.0																				
GSSX-2050-100	100	445	EF-PS130	M6 x 1.0																				
GSSX-2050-110	110	489	EF-PS130	M6 x 1.0																				
GSSX-2050-120	120	534	EF-PS130	M6 x 1.0																				
GSSX-4240-11	0.236	6.0	0.591	15.0	3.94	100	9.45	240	10.87	276											11.2	45	EF-PS130	M6 x 1.0
GSSX-4240-22																					22.5	100	EF-PS130	M6 x 1.0
GSSX-4240-33																					33.7	150	EF-PS130	M6 x 1.0
GSSX-4240-45											45.0	200	EF-PS130	M6 x 1.0										
GSSX-4240-56											56.2	250	EF-PS130	M6 x 1.0										
GSSX-4240-67											67.4	300	EF-PS130	M6 x 1.0										
GSSX-4240-78											78.7	350	EF-PS130	M6 x 1.0										
GSSX-4240-89											89.9	400	EF-PS130	M6 x 1.0										
GSSX-2249-22											0.315	8.0	0.709	18.0	3.94	100	9.80	249	11.22	285	22.5	100	EF-PS130	M6 x 1.0
GSSX-2249-33	33.7	150	EF-PS130	M6 x 1.0																				
GSSX-2249-56	56.2	250	EF-PS130	M6 x 1.0																				
GSSX-2249-89	89.9	400	EF-PS130	M6 x 1.0																				
GSSX-2249-118	118.0	525	EF-PS130	M6 x 1.0																				
GSSX-2249-146	146.0	650	EF-PS130	M6 x 1.0																				
GSSX-3249-22	0.394	10.0	0.866	22.0	3.94	100	9.80	249	12.16	309	22.5	95	EF-PS100SS	M8 x 1.25										
GSSX-3249-33											33.7	150	EF-PS100SS	M8 x 1.25										
GSSX-3249-56											56.2	250	EF-PS100SS	M8 x 1.25										
GSSX-3249-101											101.0	450	EF-PS100SS	M8 x 1.25										
GSSX-3249-157											157.4	700	EF-PS100SS	M8 x 1.25										
GSSX-3249-202											202.3	900	EF-PS100SS	M8 x 1.25										
GSSX-3249-270											270.0	1200	EF-PS100SS	M8 x 1.25										
GSSX-2100-20	0.315	8.0	0.709	18.0	3.50	89	10.48	266	11.90	300	20	95	EF-PS130	M6 x 1.0										
GSSX-2100-30											30	133	EF-PS130	M6 x 1.0										
GSSX-2100-40											40	178	EF-PS130	M6 x 1.0										

*Indicates New Metric Line
BOLD Indicates New Item
 For force in Newtons (N), multiply pounds (lbs.) by 4.448.

Other end fittings are available. Please see pages 67 and 80-81 for instructions and complete details.
 Other forces available upon request.

GSSX Stainless Steel Gas Springs

Catalog Number	Rod Diameter (D)		Tube O.D.		Stroke (S)		Base Length (BL) Cylinder		Extended Length (L)		Force		End Fitting	Thread
GSSX-2100-50	0.315	8.0	0.709	18.0	3.50	89	10.48	266	11.90	300	50	224	EF-PS130	M6 x 1.0
GSSX-2100-60											60	267	EF-PS130	M6 x 1.0
GSSX-2100-70											70	311	EF-PS130	M6 x 1.0
GSSX-2100-80											80	356	EF-PS130	M6 x 1.0
GSSX-2100-90											90	400	EF-PS130	M6 x 1.0
GSSX-2100-100											100	445	EF-PS130	M6 x 1.0
GSSX-2100-110											110	489	EF-PS130	M6 x 1.0
GSSX-2100-120											120	534	EF-PS130	M6 x 1.0
GSSX-2100-150											150	667	EF-PS130	M6 x 1.0
GSSX-5100-10											0.236	6.0	0.591	15.0
GSSX-5100-20	20	95	EF-PS130	M6 x 1.0										
GSSX-5100-30	30	133	EF-PS130	M6 x 1.0										
GSSX-5100-40	40	178	EF-PS130	M6 x 1.0										
GSSX-5100-50	50	224	EF-PS130	M6 x 1.0										
GSSX-5100-60	60	267	EF-PS130	M6 x 1.0										
GSSX-5100-90	0.315	8.0	0.709	18.0	3.50	89	10.58	269	12.00	305	90	400	EF-PS130	M6 x 1.0
S06GAM0045	0.236	6.0	0.591	15.0	4.72	120	11.02	280			10	45	NONE	M6 x 1.0
S08GAN0095	0.315	8.0	0.709	18.0	4.72	120	11.38	289			20	95	NONE	M6 x 1.0
S14FAK0200	0.551	14.0	1.102	28.0	3.94	100	10.47	266			45	200	NONE	M10 x 1.5
S08HAO0095	0.315	8.0	0.709	18.0	5.51	140	12.95	329			20	95	NONE	M6 x 1.0
GSSX-4340-11	0.236	6.0	0.591	15.0	6.00	153	13.39	340	14.80	376	10	45	EF-PS130	M6 x 1.0
GSSX-4340-22											22.5	100	EF-PS130	M6 x 1.0
GSSX-4340-33											33.7	150	EF-PS130	M6 x 1.0
GSSX-4340-45											45.0	200	EF-PS130	M6 x 1.0
GSSX-4340-56											56.2	250	EF-PS130	M6 x 1.0
GSSX-4340-67											67.4	300	EF-PS130	M6 x 1.0
GSSX-4340-78											78.7	350	EF-PS130	M6 x 1.0
GSSX-5150-10											0.236	6.0	0.591	15.0
GSSX-5150-20	20	95	EF-PS130	M6 x 1.0										
GSSX-5150-30	30	133	EF-PS130	M6 x 1.0										
GSSX-5150-40	40	178	EF-PS130	M6 x 1.0										
GSSX-5150-50	50	224	EF-PS130	M6 x 1.0										
GSSX-5150-60	60	267	EF-PS130	M6 x 1.0										
GSSX-5150-80	80	356	EF-PS130	M6 x 1.0										
GSSX-2125-20	0.315	8.0	0.709	18.0	6.00	153	13.58	345	15.00	380				
GSSX-2125-30											30	133	EF-PS130	M6 x 1.0
GSSX-2125-40											40	178	EF-PS130	M6 x 1.0
GSSX-2125-50											50	224	EF-PS130	M6 x 1.0
GSSX-2125-60											60	267	EF-PS130	M6 x 1.0
GSSX-2125-70											70	311	EF-PS130	M6 x 1.0
GSSX-2125-80											80	356	EF-PS130	M6 x 1.0
GSSX-2125-90											90	400	EF-PS130	M6 x 1.0
GSSX-2125-100											100	445	EF-PS130	M6 x 1.0
GSSX-2125-110											110	489	EF-PS130	M6 x 1.0
GSSX-2125-120											120	534	EF-PS130	M6 x 1.0
GSSX-2349-22											0.315	8.0	0.709	18.0
GSSX-2349-33	33.7	150	EF-PS130	M6 x 1.0										
GSSX-2349-56	56.2	250	EF-PS130	M6 x 1.0										
GSSX-2349-89	89.9	400	EF-PS130	M6 x 1.0										

*Indicates New Metric Line
BOLD Indicates New Item

Other end fittings are available. Please see pages 67 and 80-81 for instructions and complete details.
Other forces available upon request.

GSSX Stainless Steel Gas Springs

Catalog Number	Rod Diameter (D)		Tube O.D.		Stroke (S)		Base Length (BL) Cylinder		Extended Length (L)		Force		End Fitting	Thread
GSSX-2349-118	0.315	8.0	0.709	18.0	6.00	153	13.74	349	15.16	385	118	525	EF-PS130	M6 x 1.0
GSSX-2349-146											146	650	EF-PS130	M6 x 1.0
GSSX-2150-20	0.315	8.0	0.709	18.0	6.00	153	13.83	351	15.25	385	20	95	EF-PS130	M6 x 1.0
GSSX-2150-30											30	133	EF-PS130	M6 x 1.0
GSSX-2150-60											60	267	EF-PS130	M6 x 1.0
GSSX-2150-90											90	400	EF-PS130	M6 x 1.0
GSSX-2150-120											120	534	EF-PS130	M6 x 1.0
GSSX-2150-150											150	667	EF-PS130	M6 x 1.0
GASX-0818-0630-020	0.315	8.0	0.709	18.0	6.30	160	14.53	369	15.95	405	20	95	EF-PS130	M6 x 1.0
S10JAR0095	0.394	10.0	0.866	23.0	5.91	150	13.74	349			21	95	NONE	M8 x 1.25
GSSX-5200-10	0.236	6.0	0.591	15.0	7.00	178	15.58	396	17.00	432	10	45	EF-PS130	M6 x 1.0
GSSX-5200-20											20	95	EF-PS130	M6 x 1.0
GSSX-5200-30											30	133	EF-PS130	M6 x 1.0
GSSX-5200-40											40	178	EF-PS130	M6 x 1.0
GSSX-5200-50											50	224	EF-PS130	M6 x 1.0
GSSX-5200-60											60	267	EF-PS130	M6 x 1.0
GSSX-5200-75											75	334	EF-PS130	M6 x 1.0
GSSX-2200-20	0.315	8.0	0.709	18.0	7.00	178	15.58	394	17.00	430	20	95	EF-PS130	M6 x 1.0
GSSX-2200-30											30	133	EF-PS130	M6 x 1.0
GSSX-2200-40											40	178	EF-PS130	M6 x 1.0
GSSX-2200-50											50	224	EF-PS130	M6 x 1.0
GSSX-2200-60											60	267	EF-PS130	M6 x 1.0
GSSX-2200-70											70	311	EF-PS130	M6 x 1.0
GSSX-2200-80											80	356	EF-PS130	M6 x 1.0
GSSX-2200-90											90	400	EF-PS130	M6 x 1.0
GSSX-2200-100											100	445	EF-PS130	M6 x 1.0
GSSX-2200-110											110	489	EF-PS130	M6 x 1.0
GSSX-2200-120											120	534	EF-PS130	M6 x 1.0
GSSX-2200-150											150	667	EF-PS130	M6 x 1.0
S14JAS0200	0.551	14.0	1.102	28.0	5.91	150	14.41	366			45	200	NONE	M10 x 1.5
S08MAV0095	0.315	8.0	0.709	18.0	7.09	180	16.10	409			20	95	NONE	M6 x 1.0
GSSX-5250-10	0.236	6.0	0.591	15.0	7.50	197	17.08	434	18.50	470	10	45	EF-PS130	M6 x 1.0
GSSX-5250-20											20	95	EF-PS130	M6 x 1.0
GSSX-5250-30											30	133	EF-PS130	M6 x 1.0
GSSX-5250-45											45	200	EF-PS130	M6 x 1.0
GSSX-5250-60											60	267	EF-PS130	M6 x 1.0
GSSX-5250-75											75	334	EF-PS130	M6 x 1.0
GSSX-2250-20	0.315	8.0	0.709	18.0	7.25	184	17.08	434	18.50	470	20	334	EF-PS130	M6 x 1.0
GSSX-2250-90											90	400	EF-PS130	M6 x 1.0
GSSX-2250-120											120	534	EF-PS130	M6 x 1.0
GSSX-2250-150											150	667	EF-PS130	M6 x 1.0
GSSX-4440-11	0.236	6.0	0.591	15.0	7.87	200	17.32	440	18.74	476.00	10	50	EF-PS130	M6 x 1.0
GSSX-4440-22											22.5	100	EF-PS130	M6 x 1.0
GSSX-4440-33											33.7	150	EF-PS130	M6 x 1.0
GSSX-4440-56											56.2	250	EF-PS130	M6 x 1.0
GSSX-4440-89											89.9	400	EF-PS130	M6 x 1.0
GSSX-2449-22	0.315	8.0	0.709	18.0	7.87	200	17.68	449	19.10	485.00	22.5	95	EF-PS130	M6 x 1.0
GSSX-2449-33											33.7	150	EF-PS130	M6 x 1.0

*Indicates New Metric Line
BOLD Indicates New Item

Other end fittings are available. Please see pages 67 and 80-81 for instructions and complete details.
 Other forces available upon request.

We reserve the right to add, delete or modify components without notification.

All dimensions are nominal unless tolerance is stated.

GSSX Stainless Steel Gas Springs

Catalog Number	Rod Diameter (D)		Tube O.D.		Stroke (S)		Base Length (BL) Cylinder		Extended Length (L)		Force		End Fitting	Thread
GSSX-2449-56	0.315	8.0	0.709	18.0	7.87	200	17.68	449	19.10	485.00	56.2	250	EF-PS130	M6 x 1.0
GSSX-2449-89											89.9	400	EF-PS130	M6 x 1.0
GSSX-2449-118											118.0	525	EF-PS130	M6 x 1.0
GSSX-2449-135											135.0	650	EF-PS130	M6 x 1.0
GSSX-1466-45	0.551	14.0	1.102	28.0	7.87	200	18.35	466	21.11	536.00	45.0	200	EF-PS140SS	M10 x 1.5
GSSX-1466-112											112.4	500	EF-PS140SS	M10 x 1.5
GSSX-1466-179											179.9	800	EF-PS140SS	M10 x 1.5
GSSX-1466-269											269.8	1200	EF-PS140SS	M10 x 1.5
GSSX-1466-359											359.7	1600	EF-PS140SS	M10 x 1.5
GSSX-1466-449											449.6	2000	EF-PS140SS	M10 x 1.5
GSSX-1466-562	562.1	2500	EF-PS140SS	M10 x 1.5										
GSSX-5300-10	0.236	6.0	0.591	15.0	8.00	203	18.58	472	20.00	508	10	45	EF-PS130	M6 x 1.0
GSSX-5300-20											20	95	EF-PS130	M6 x 1.0
GSSX-5300-30											30	133	EF-PS130	M6 x 1.0
GSSX-5300-40											40	178	EF-PS130	M6 x 1.0
GSSX-5300-50											50	224	EF-PS130	M6 x 1.0
GSSX-5300-60											60	267	EF-PS130	M6 x 1.0
GSSX-2300-20	0.315	8.0	0.709	18.0	8.00	203	18.58	472	20.00	508	20	95	EF-PS130	M6 x 1.0
GSSX-2300-30											30	133	EF-PS130	M6 x 1.0
GSSX-2300-40											40	178	EF-PS130	M6 x 1.0
GSSX-2300-50											50	224	EF-PS130	M6 x 1.0
GSSX-2300-60											60	267	EF-PS130	M6 x 1.0
GSSX-2300-70											70	311	EF-PS130	M6 x 1.0
GSSX-2300-75											75	334	EF-PS130	M6 x 1.0
GSSX-2300-80											80	356	EF-PS130	M6 x 1.0
GSSX-2300-90											90	400	EF-PS130	M6 x 1.0
GSSX-2300-100											100	445	EF-PS130	M6 x 1.0
GSSX-2300-110											110	489	EF-PS130	M6 x 1.0
GSSX-2300-120											120	534	EF-PS130	M6 x 1.0
GSSX-2300-130											130	578	EF-PS130	M6 x 1.0
GSSX-2300-150											150	667	EF-PS130	M6 x 1.0
GSSX-3020-20	0.394	10.0	0.866	23.0	7.87	200	17.84	453	20.20	513	21	95	EF-PS100SS	M8 x 1.25
GSSX-3020-30											30	133	EF-PS100SS	M8 x 1.25
GSSX-3020-40											40	178	EF-PS100SS	M8 x 1.25
GSSX-3020-50											50	224	EF-PS100SS	M8 x 1.25
GSSX-3020-60											60	267	EF-PS100SS	M8 x 1.25
GSSX-3020-70											70	311	EF-PS100SS	M8 x 1.25
GSSX-3020-80											80	356	EF-PS100SS	M8 x 1.25
GSSX-3020-90											90	400	EF-PS100SS	M8 x 1.25
GSSX-3020-100											100	445	EF-PS100SS	M8 x 1.25
GSSX-3020-110											110	489	EF-PS100SS	M8 x 1.25
GSSX-3020-120											120	534	EF-PS100SS	M8 x 1.25
GSSX-3020-130											130	578	EF-PS100SS	M8 x 1.25
GSSX-3020-140											140	623	EF-PS100SS	M8 x 1.25
GSSX-3020-150											150	667	EF-PS100SS	M8 x 1.25
GSSX-3020-160	160	712	EF-PS100SS	M8 x 1.25										
GSSX-3020-170	170	756	EF-PS100SS	M8 x 1.25										
GSSX-3020-180	180	801	EF-PS100SS	M8 x 1.25										

*Indicates New Metric Line
BOLD Indicates New Item

For force in Newtons (N), multiply pounds (lbs.) by 4.448.

Other end fittings are available. Please see pages 67 and 80-81 for instructions and complete details.
Other forces available upon request.

GSSX Stainless Steel Gas Springs

Catalog Number	Rod Diameter (D)		Tube O.D.		Stroke (S)		Base Length (BL) Cylinder		Extended Length (L)		Force		End Fitting	Thread										
S080BB0095	0.315	8.0	0.709	18.0	8.66	220	19.25	489			20	95	NONE	M6 x 1.0										
GSSX-2400-20	0.315	8.0	0.709	18.0	9.84	250	21.61	549	23.03	585	20	95	EF-PS130	M6 x 1.0										
GSSX-2400-30											30	133	EF-PS130	M6 x 1.0										
GSSX-2400-40											40	178	EF-PS130	M6 x 1.0										
GSSX-2400-50											50	224	EF-PS130	M6 x 1.0										
GSSX-2400-60											60	267	EF-PS130	M6 x 1.0										
GSSX-2400-70											70	311	EF-PS130	M6 x 1.0										
GSSX-2400-80											80	356	EF-PS130	M6 x 1.0										
GSSX-2400-90											90	400	EF-PS130	M6 x 1.0										
GSSX-2400-100											100	445	EF-PS130	M6 x 1.0										
GSSX-2400-110											110	489	EF-PS130	M6 x 1.0										
GSSX-2400-120											120	534	EF-PS130	M6 x 1.0										
GSSX-3549-22											0.394	10.0	0.866	23.0	9.84	250	21.61	549	23.97	610	22.5	95	EF-PS100SS	M8 x 1.25
GSSX-3549-33	33.7	150	EF-PS100SS	M8 x 1.25																				
GSSX-3549-56	56.2	250	EF-PS100SS	M8 x 1.25																				
GSSX-3549-101	101.2	450	EF-PS100SS	M8 x 1.25																				
GSSX-3549-157	157.4	700	EF-PS100SS	M8 x 1.25																				
GSSX-3549-202	202.3	900	EF-PS100SS	M8 x 1.25																				
GSSX-3549-269	269.8	1200	EF-PS100SS	M8 x 1.25																				
S14PBD0200	0.551	14.0	1.102	28.0	9.84	250	22.28	566			45	200	NONE	M10 x 1.5										
GSSX-2600-20	0.315	8.0	0.709	18.0	11.00	279	24.88	632	26.30	668	20	95	EF-PS90M1SS	M6 x 1.0										
GSSX-2600-30											30	133	EF-PS90M1SS	M6 x 1.0										
GSSX-2600-40											40	178	EF-PS90M1SS	M6 x 1.0										
GSSX-2600-50											50	224	EF-PS90M1SS	M6 x 1.0										
GSSX-2600-60											60	267	EF-PS90M1SS	M6 x 1.0										
GSSX-2600-70											70	311	EF-PS90M1SS	M6 x 1.0										
GSSX-2600-80											80	356	EF-PS90M1SS	M6 x 1.0										
GSSX-2600-90											90	400	EF-PS90M1SS	M6 x 1.0										
GSSX-2600-100											100	445	EF-PS90M1SS	M6 x 1.0										
GSSX-2600-110											110	489	EF-PS90M1SS	M6 x 1.0										
GSSX-2600-120											120	534	EF-PS90M1SS	M6 x 1.0										
GSSX-2600-150											150	667	EF-PS90M1SS	M6 x 1.0										
GSSX-3000-30											0.394	10.0	0.866	22.0	11.81	300	25.55	649	26.97	685	30	133	EF-PS90M1SS	M6 x 1.0
GSSX-3000-40																					40	178	EF-PS90M1SS	M6 x 1.0
GSSX-3000-50																					50	224	EF-PS90M1SS	M6 x 1.0
GSSX-3000-60	60	267	EF-PS90M1SS	M6 x 1.0																				
GSSX-3000-70	70	311	EF-PS90M1SS	M6 x 1.0																				
GSSX-3000-80	80	356	EF-PS90M1SS	M6 x 1.0																				
GSSX-3000-90	90	400	EF-PS90M1SS	M6 x 1.0																				
GSSX-3000-100	100	445	EF-PS90M1SS	M6 x 1.0																				
GSSX-3000-110	110	489	EF-PS90M1SS	M6 x 1.0																				
GSSX-3000-120	120	534	EF-PS90M1SS	M6 x 1.0																				
GSSX-3000-130	130	578	EF-PS90M1SS	M6 x 1.0																				
GSSX-3000-140	140	623	EF-PS90M1SS	M6 x 1.0																				
GSSX-3000-150	150	667	EF-PS90M1SS	M6 x 1.0																				
GSSX-3000-160	160	712	EF-PS90M1SS	M6 x 1.0																				
GSSX-3000-170	170	756	EF-PS90M1SS	M6 x 1.0																				
GSSX-3000-180	180	801	EF-PS90M1SS	M6 x 1.0																				

*Indicates New Metric Line
BOLD Indicates New Item
 For force in Newtons (N), multiply pounds (lbs.) by 4.448.

Other end fittings are available. Please see pages 67 and 80-81 for instructions and complete details.
 Other forces available upon request.

We reserve the right to add, delete or modify components without notification.
 All dimensions are stated in mm.
 All dimensions are nominal unless tolerance is stated.

GSSX Stainless Steel Gas Springs

Catalog Number	Rod Diameter (D)		Tube O.D.		Stroke (S)		Base Length (BL) Cylinder		Extended Length (L)		Force		End Fitting	Thread
GSSX-3050-20	0.394	10.0	0.866	22.0	11.81	300	25.55	649	26.97	685	21	95	EF-PS90M1SS	M6 x 1.0
GSSX-3050-30											30	133	EF-PS90M1SS	M6 x 1.0
GSSX-3050-40											40	178	EF-PS90M1SS	M6 x 1.0
GSSX-3050-50											50	224	EF-PS90M1SS	M6 x 1.0
GSSX-3050-60											60	267	EF-PS90M1SS	M6 x 1.0
GSSX-3050-70											70	311	EF-PS90M1SS	M6 x 1.0
GSSX-3050-80											80	356	EF-PS90M1SS	M6 x 1.0
GSSX-3050-90											90	400	EF-PS90M1SS	M6 x 1.0
GSSX-3050-100											100	445	EF-PS90M1SS	M6 x 1.0
GSSX-3050-110											110	489	EF-PS90M1SS	M6 x 1.0
GSSX-3050-120											120	534	EF-PS90M1SS	M6 x 1.0
GSSX-3050-130											130	578	EF-PS90M1SS	M6 x 1.0
GSSX-3050-140											140	623	EF-PS90M1SS	M6 x 1.0
GSSX-3050-150											150	667	EF-PS90M1SS	M6 x 1.0
GSSX-3050-160											160	712	EF-PS90M1SS	M6 x 1.0
GSSX-3050-170											170	756	EF-PS90M1SS	M6 x 1.0
GSSX-3050-180											180	801	EF-PS90M1SS	M6 x 1.0
GSSX-1666-45											0.551	14.0	1.102	28.0
GSSX-1666-111	111.6	500	EF-PS140SS	M10 x 1.5										
GSSX-1666-179	179.9	800	EF-PS140SS	M10 x 1.5										
GSSX-1666-269	269.8	1200	EF-PS140SS	M10 x 1.5										
GSSX-1666-359	359.7	1600	EF-PS140SS	M10 x 1.5										
GSSX-1666-449	449.6	2000	EF-PS140SS	M10 x 1.5										
GSSX-1666-562	562.1	2500	EF-PS140SS	M10 x 1.5										
GSSX-2800-20	0.315	8.0	0.709	18.0	11.50	292	26.58	675	28.00	711	20	95	EF-PS130	M6 x 1.0
GSSX-2800-30											30	133	EF-PS130	M6 x 1.0
GSSX-2800-40											40	178	EF-PS130	M6 x 1.0
GSSX-2800-50											50	224	EF-PS130	M6 x 1.0
GSSX-2800-60											60	267	EF-PS130	M6 x 1.0
GSSX-2800-70											70	311	EF-PS130	M6 x 1.0
GSSX-2800-80											80	356	EF-PS130	M6 x 1.0
GSSX-2800-90											90	400	EF-PS130	M6 x 1.0
GSSX-2800-100											100	445	EF-PS130	M6 x 1.0
GSSX-2800-110											110	489	EF-PS130	M6 x 1.0
GSSX-2800-120											120	534	EF-PS130	M6 x 1.0
GSSX-2800-130											130	578	EF-PS130	M6 x 1.0
GSSX-2800-140											140	623	EF-PS130	M6 x 1.0
GSSX-2800-150											150	667	EF-PS130	M6 x 1.0
GSSX-3100-20											0.394	10.0	0.866	22.0
GSSX-3100-30	30	133	EF-PS100SS	M8 x 1.25										
GSSX-3100-40	40	178	EF-PS100SS	M8 x 1.25										
GSSX-3100-50	50	224	EF-PS100SS	M8 x 1.25										
GSSX-3100-60	60	267	EF-PS100SS	M8 x 1.25										
GSSX-3100-70	70	311	EF-PS100SS	M8 x 1.25										
GSSX-3100-80	80	356	EF-PS100SS	M8 x 1.25										
GSSX-3100-90	90	400	EF-PS100SS	M8 x 1.25										
GSSX-3100-100	100	445	EF-PS100SS	M8 x 1.25										
GSSX-3100-110	110	489	EF-PS100SS	M8 x 1.25										
GSSX-3100-120	120	534	EF-PS100SS	M8 x 1.25										

*Indicates New Metric Line
BOLD Indicates New Item

Other end fittings are available. Please see pages 67 and 80-81 for instructions and complete details.
Other forces available upon request.

GSSX Stainless Steel Gas Springs

Catalog Number	Rod Diameter (D)		Tube O.D.		Stroke (S)		Base Length (BL) Cylinder		Extended Length (L)		Force		End Fitting	Thread
GSSX-3100-130	0.394	10.0	0.866	22.0	11.50	292	25.64	651	28.00	711	130	578	EF-PS100SS	M8 x 1.25
GSSX-3100-140											140	623	EF-PS100SS	M8 x 1.25
GSSX-3100-150											150	667	EF-PS100SS	M8 x 1.25
GSSX-3100-160											160	712	EF-PS100SS	M8 x 1.25
GSSX-3100-170											170	756	EF-PS100SS	M8 x 1.25
GSSX-3100-175											175	778	EF-PS100SS	M8 x 1.25
GSSX-3100-180											180	801	EF-PS100SS	M8 x 1.25
GSSX-3100-200											200	890	EF-PS100SS	M8 x 1.25
GSSX-3100-250											250	1112	EF-PS100SS	M8 x 1.25
GSSX-3200-20											0.394	10.0	0.866	22.0
GSSX-3200-30	30	133	EF-PS90M1SS	M6 x 1.0										
GSSX-3200-40	40	178	EF-PS90M1SS	M6 x 1.0										
GSSX-3200-50	50	224	EF-PS90M1SS	M6 x 1.0										
GSSX-3200-60	60	267	EF-PS90M1SS	M6 x 1.0										
GSSX-3200-70	70	311	EF-PS90M1SS	M6 x 1.0										
GSSX-3200-80	80	356	EF-PS90M1SS	M6 x 1.0										
GSSX-3200-90	90	400	EF-PS90M1SS	M6 x 1.0										
GSSX-3200-100	100	445	EF-PS90M1SS	M6 x 1.0										
GSSX-3200-110	110	489	EF-PS90M1SS	M6 x 1.0										
GSSX-3200-120	120	534	EF-PS90M1SS	M6 x 1.0										
GSSX-3200-130	130	578	EF-PS90M1SS	M6 x 1.0										
GSSX-3200-140	140	623	EF-PS90M1SS	M6 x 1.0										
GSSX-3200-150	150	667	EF-PS90M1SS	M6 x 1.0										
GSSX-3200-160	160	712	EF-PS90M1SS	M6 x 1.0										
GSSX-3200-170	170	756	EF-PS90M1SS	M6 x 1.0										
GSSX-3200-180	180	801	EF-PS90M1SS	M6 x 1.0										
S14SBJ0200	0.551	14.0	1.102	28.0	13.78	350	30.16	766						
GSSX-3849-22	0.394	10.0	0.866	23.0	15.75	400	33.43	849	35.79	910	21	95	EF-PS100SS	M8 x 1.25
GSSX-3849-33											33.7	150	EF-PS100SS	M8 x 1.25
GSSX-3849-56											56.2	250	EF-PS100SS	M8 x 1.25
GSSX-3849-101											101.2	450	EF-PS100SS	M8 x 1.25
GSSX-3849-157											157.4	700	EF-PS100SS	M8 x 1.25
GSSX-3849-202											202.3	900	EF-PS100SS	M8 x 1.25
GSSX-3849-269											269.8	1200	EF-PS100SS	M8 x 1.25
GSSX-3610-30	0.394	10.0	0.866	22.0	15.2	386	34.88	886	36.3	668	30	133	EF-PS90M1SS	M6 x 1.0
GSSX-3610-40											40	178	EF-PS90M1SS	M6 x 1.0
GSSX-3610-50											50	224	EF-PS90M1SS	M6 x 1.0
GSSX-3610-60											60	267	EF-PS90M1SS	M6 x 1.0
GSSX-3610-70											70	311	EF-PS90M1SS	M6 x 1.0
GSSX-3610-80											80	356	EF-PS90M1SS	M6 x 1.0
GSSX-3610-90											90	400	EF-PS90M1SS	M6 x 1.0
GSSX-3610-100											100	445	EF-PS90M1SS	M6 x 1.0
GSSX-3610-110											110	489	EF-PS90M1SS	M6 x 1.0
GSSX-3610-120											120	534	EF-PS90M1SS	M6 x 1.0
GSSX-3610-130											130	578	EF-PS90M1SS	M6 x 1.0
GSSX-3610-140											140	623	EF-PS90M1SS	M6 x 1.0
GSSX-3610-150											150	667	EF-PS90M1SS	M6 x 1.0
GSSX-3610-160											160	712	EF-PS90M1SS	M6 x 1.0
GSSX-3610-170	170	756	EF-PS90M1SS	M6 x 1.0										

*Indicates New Metric Line
BOLD Indicates New Item

Other end fittings are available. Please see pages 67 and 80-81 for instructions and complete details.
 Other forces available upon request.

We reserve the right to add, delete or modify components without notification.
 All dimensions are stated in mm.
 All dimensions are nominal unless tolerance is stated.

GSSX Stainless Steel Gas Springs

Catalog Number	Rod Diameter (D)		Tube O.D.		Stroke (S)		Base Length (BL) Cylinder		Extended Length (L)		Force		End Fitting	Thread										
GSSX-3610-180	0.394	10.0	0.866	22.0	15.2	386	34.88	886	36.3	668	180	801	EF-PS90M1SS	M6 x 1.0										
GSSX-3600-30	0.394	10.0	0.866	22.0	15.2	386	33.94	862	36.3	668	30	133	EF-PS100SS	M8 x 1.25										
GSSX-3600-40											40	178	EF-PS100SS	M8 x 1.25										
GSSX-3600-50											50	224	EF-PS100SS	M8 x 1.25										
GSSX-3600-60											60	267	EF-PS100SS	M8 x 1.25										
GSSX-3600-70											70	311	EF-PS100SS	M8 x 1.25										
GSSX-3600-80											80	356	EF-PS100SS	M8 x 1.25										
GSSX-3600-90											90	400	EF-PS100SS	M8 x 1.25										
GSSX-3600-100											100	445	EF-PS100SS	M8 x 1.25										
GSSX-3600-110											110	489	EF-PS100SS	M8 x 1.25										
GSSX-3600-120											120	534	EF-PS100SS	M8 x 1.25										
GSSX-3600-130											130	578	EF-PS100SS	M8 x 1.25										
GSSX-3600-140											140	623	EF-PS100SS	M8 x 1.25										
GSSX-3600-150											150	667	EF-PS100SS	M8 x 1.25										
GSSX-3600-160											160	712	EF-PS100SS	M8 x 1.25										
GSSX-3600-170											170	756	EF-PS100SS	M8 x 1.25										
GSSX-3600-180											180	801	EF-PS100SS	M8 x 1.25										
GSSX-1866-45											0.551	14.0	1.102	28.0	15.75	400	34.88	866	37.64	956	45	200	EF-PS140SS	M10 x 1.5
GSSX-1866-112																					112.4	500	EF-PS140SS	M10 x 1.5
GSSX-1866-179	179.9	800	EF-PS140SS	M10 x 1.5																				
GSSX-1866-269	269.8	1200	EF-PS140SS	M10 x 1.5																				
GSSX-1866-359	359.7	1600	EF-PS140SS	M10 x 1.5																				
GSSX-1866-449	449.6	2000	EF-PS140SS	M10 x 1.5																				
GSSX-1866-562	562.1	2500	EF-PS140SS	M10 x 1.5																				
GSSX-1066-45	0.551	14.0	1.102	28.0	19.69	500	41.97	1066	44.73	1136											45	200	EF-PS140SS	M10 x 1.5
GSSX-1066-112											112.4	500	EF-PS140SS	M10 x 1.5										
GSSX-1066-179											179.9	800	EF-PS140SS	M10 x 1.5										
GSSX-1066-269											269.8	1200	EF-PS140SS	M10 x 1.5										
GSSX-1066-359											359.7	1600	EF-PS140SS	M10 x 1.5										
GSSX-1066-449											449.6	2000	EF-PS140SS	M10 x 1.5										
GSSX-1066-562											562.1	2500	EF-PS140SS	M10 x 1.5										

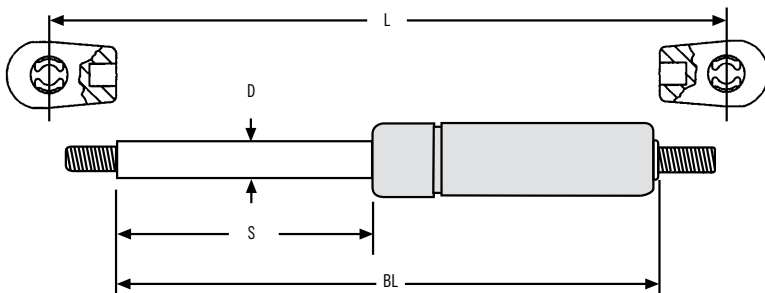

*Indicates New Metric Line
BOLD Indicates New Item

Other end fittings are available. Please see pages 67 and 80-81 for instructions and complete details.
Other forces available upon request.

The **GSEL Gas Spring** eliminates the need for a separate safety rod or support in critical lift-assist applications. The shroud positively locks when the gas spring is fully extended protecting people and critical equipment from injury or harm in the event of catastrophic gas spring failure due to excessive overload or misuse. The **GSEL Gas Spring** is simple to use, when the gas spring is fully extended a spring loaded locking shroud moves into place on the lip of the tube to prevent the gas spring from compressing. The shroud is released by applying thumb pressure to move shroud out of the way so the gas spring may compress.

The locking shroud on the **Shock-Lock™ Gas Spring** is finished with the same baked on epoxy finish as the gas spring tube. The gas spring has a black nitride shaft providing excellent corrosion resistance as well as an attractive appearance.



• Stock items in bold, all other sizes are available as a special order

PART NUMBERS

Catalog Number	Rod Diameter (D)		Tube O.D.		Stroke (S)		Base Length (BL) Cylinder		Extended Length (L)		Force		End Fitting	Thread
	in	mm	in	mm	in	mm	in	mm	in	mm	lbs	N		
GSEL-4900-20	0.236	6.0	0.591	15.0	2.00	51	6.08	154	7.50	191	20	89	EF-PS30B1	M6 x 1.0
GSEL-4900-30											30	133	EF-PS30B1	M6 x 1.0
GSEL-4900-40											40	178	EF-PS30B1	M6 x 1.0
GSEL-4900-60											60	267	EF-PS30B1	M6 x 1.0
GSEL-4900-80											80	356	EF-PS30B1	M6 x 1.0
GSEL-5000-20	0.236	6.0	0.591	15.0	3.00	76	8.58	218	10.00	254	20	89	EF-PS30B1	M6 x 1.0
GSEL-5000-30											30	133	EF-PS30B1	M6 x 1.0
GSEL-5000-40											40	178	EF-PS30B1	M6 x 1.0
GSEL-5000-60											60	267	EF-PS30B1	M6 x 1.0
GSEL-5000-80											80	356	EF-PS30B1	M6 x 1.0
GSEL-2100-120	0.315	8.0	0.708	18.0	3.50	89	10.48	266	11.90	302	120	534	EF-PS30B1	M6 x 1.0
GSEL-2100-150											150	667	EF-PS30B1	M6 x 1.0
GSEL-5100-20	0.236	6.0	0.591	15.0	3.50	89	10.58	269	12.00	305	20	89	EF-PS30B1	M6 x 1.0
GSEL-5100-30											30	133	EF-PS30B1	M6 x 1.0
GSEL-5100-40											40	178	EF-PS30B1	M6 x 1.0
GSEL-5100-60											60	267	EF-PS30B1	M6 x 1.0
GSEL-5150-20	0.236	6.0	0.591	15.0	5.50	140	13.58	345	15.00	381	20	89	EF-PS30B1	M6 x 1.0
GSEL-5150-30											30	133	EF-PS30B1	M6 x 1.0
GSEL-5150-40											40	178	EF-PS30B1	M6 x 1.0
GSEL-5150-60											60	267	EF-PS30B1	M6 x 1.0
GSEL-5150-80											80	356	EF-PS30B1	M6 x 1.0
GSEL-2150-90	0.315	8.0	0.708	18.0	5.50	140	13.83	351	15.25	387	90	400	EF-PS30B1	M6 x 1.0
GSEL-2150-120											120	534	EF-PS30B1	M6 x 1.0
GSEL-2150-150											150	667	EF-PS30B1	M6 x 1.0
GSEL-5200-20	0.236	6.0	0.591	15.0	6.75	171	15.58	396	17.00	432	20	89	EF-PS30B1	M6 x 1.0
GSEL-5200-30											30	133	EF-PS30B1	M6 x 1.0
GSEL-5200-40											40	178	EF-PS30B1	M6 x 1.0
GSEL-5200-50											50	222	EF-PS30B1	M6 x 1.0
GSEL-5200-60											60	267	EF-PS30B1	M6 x 1.0
GSEL-5200-75											75	334	EF-PS30B1	M6 x 1.0
GSEL-2200-90	0.315	8.0	0.708	18.0	6.00	152	15.58	396	17.00	432	90	400	EF-PS30B1	M6 x 1.0
GSEL-2200-120											120	534	EF-PS30B1	M6 x 1.0
GSEL-2200-150											150	667	EF-PS30B1	M6 x 1.0
GSEL-5250-20	0.236	6.0	0.591	15.0	7.25	184	17.08	434	18.50	470	20	89	EF-PS30B1	M6 x 1.0
GSEL-5250-30											30	133	EF-PS30B1	M6 x 1.0
GSEL-5250-45											45	200	EF-PS30B1	M6 x 1.0
GSEL-5250-60											60	267	EF-PS30B1	M6 x 1.0

Other end fittings are available. Please see pages 67 and 80-81 for instructions and complete details.

We reserve the right to add, delete or modify components without notification.

All dimensions are stated in mm.

All dimensions are nominal unless tolerance is stated.

Catalog Number	Rod Diameter (D)		Tube O.D.		Stroke (S)		Base Length (BL) Cylinder		Extended Length (L)		Force		End Fitting	Thread
	in	mm	in	mm	in	mm	in	mm	in	mm	lbs	N		
GSEL-5250-75	0.236	6.0	0.591	15.0	7.25	184	17.08	434	18.50	470	75	334	EF-PS30B1	M6 x 1.0
GSEL-2250-120	0.315	8.0	0.708	18.0	7.25	184	17.08	434	18.50	470	120	534	EF-PS30B1	M6 x 1.0
GSEL-2250-150											150	667	EF-PS30B1	M6 x 1.0
GSEL-5300-20	0.236	6.0	0.591	15.0	8.00	203	18.58	472	20.00	508	20	89	EF-PS30B1	M6 x 1.0
GSEL-5300-30											30	133	EF-PS30B1	M6 x 1.0
GSEL-5300-40											40	178	EF-PS30B1	M6 x 1.0
GSEL-5300-50											50	222	EF-PS30B1	M6 x 1.0
GSEL-5300-60											60	267	EF-PS30B1	M6 x 1.0
GSEL-5300-70											70	311	EF-PS30B1	M6 x 1.0
GSEL-5300-80											80	356	EF-PS30B1	M6 x 1.0
GSEL-2300-90											0.315	8.0	0.708	18.0
GSEL-2300-120	120	534	EF-PS30B1	M6 x 1.0										
GSEL-2300-150	150	667	EF-PS30B1	M6 x 1.0										
GSEL-3100-100	0.394	10.0	0.866	22.0	11.50	292	26.34	669	28.00	711	100	445	EF-PS100	M8 x 1.25
GSEL-3100-120											120	534	EF-PS100	M8 x 1.25
GSEL-3100-150											150	667	EF-PS100	M8 x 1.25
GSEL-3100-200											200	890	EF-PS100	M8 x 1.25
GSEL-3100-250											250	1112	EF-PS100	M8 x 1.25

Other end fittings are available. Please see pages 67 and 80-81 for instructions and complete details.

GSVL Varilift Gas Springs

Introducing the new GSVL *Varilift* gas spring! This unique gas spring comes with a bleeder valve so the end user can adjust the P1 force of the gas spring to fit the application. Each size gas springs comes with the maximum P1 force available for that series gas spring. Once the Varilift is installed the nitrogen gas can gradually be released until a suitable force has been achieved. Once established the Varilift can be returned to SPD to determine the new force and a suitable less expensive fixed force gas spring can be provided for your precise application. The Varilift Gas Spring also has the added features of a black nitride shaft and the ability to be adjusted while in position saving both the time and effort of removing the gas spring from the application and bleeding the valve over and over again until the proper force is reached.

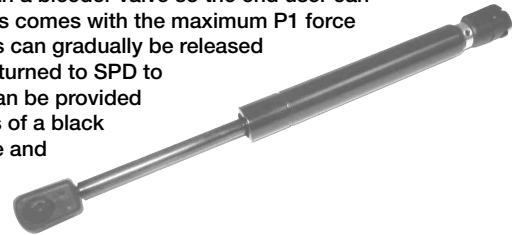

The *GSVL Gas Spring* is an excellent choice for prototyping new applications and for use where the gas spring size is the same but the weights of the lids vary.

PART NUMBERS

Catalog Number	Rod Diameter (D)		Tube O.D.		Stroke (S)		"Base Cylinder Length (BL)"		Extended Length (L)		Force		End Fitting	Thread
	in	mm	in	mm	in	mm	in	mm	in	mm	lbs	N		
GSVL-4900-100	0.236	6.0	0.591	15.0	2.00	51	6.06	154	7.50	190	100	445	EF-PS30B1	M6 x 1.0
GSVL-5000-100	0.236	6.0	0.591	15.0	3.00	76	8.58	218	10.00	254	100	445	EF-PS30B1	M6 x 1.0
GSVL-2100-150	0.315	8.0	0.709	18.0	3.54	90	10.48	266	11.90	300	150	667	EF-PS30B1	M6 x 1.0
GSVL-5150-100	0.236	6.0	0.591	15.0	5.51	140	13.58	345	15.00	380	100	445	EF-PS30B1	M6 x 1.0
GSVL-2150-150	0.315	8.0	0.709	18.0	5.51	140	13.83	351	15.25	385	150	667	EF-PS30B1	M6 x 1.0
GSVL-2200-150	0.315	8.0	0.709	18.0	6.00	150	15.58	396	17.00	430	150	667	EF-PS30B1	M6 x 1.0
GSVL-2250-150	0.315	8.0	0.709	18.0	7.25	180	17.08	434	18.50	470	150	667	EF-PS30B1	M6 x 1.0
GSVL-2300-150	0.315	8.0	0.709	18.0	8.00	200	18.58	472	20.00	508	150	667	EF-PS30B1	M6 x 1.0
GSVL-3100-250	0.394	10.0	0.866	22.0	11.50	292	25.64	651	28.00	711	250	1110	EF-PS100BP	M8 x 1.25

Other end fittings are available. Please see pages 67 and 80-81 for instructions and complete details.

Specifying Optional Gas Spring End Fittings

To select end fittings other than those specified as standard and listed in the gas spring part number tables, use the following designation:

(see sample part number example below)

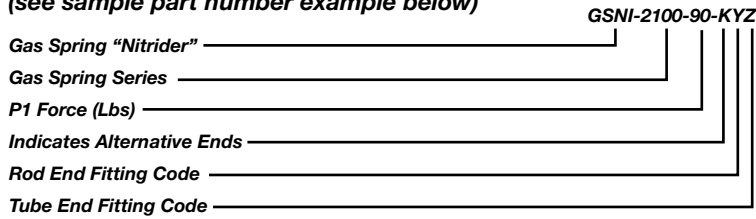

Example: To order a GSNI-2100-90 with an EF-PS91 Rod End Fitting and an EF-PS122 Tube End Fitting the new part number would be: GSNI-2100-90-KET.

End Fitting Code List

End Fitting	Designation Code
EF-PS30B1	A
EF-PS30G1	B
EF-PS130	C
EF-PS30B2	D
EF-PS91	E
EF-PS91BP	F
EF-12788	G
EF-PS90	H

End Fitting	Designation Code
EF-PS90SS	I
EF-PS90BP	J
EF-PS90M1	L
EF-PS90M1-SS	M
EF-PS90M1BP	N
EF-PS100	O
EF-PS100SS	P
EF-PS100BP	Q

End Fitting	Designation Code
EF-PS120	R
EF-PS121	S
EF-PS122	T
EF-PS123	U
EF-PS124	V
EF-PS30B3	W
EF-13857	X
No fitting	Z

Note: When specifying alternative end fittings, ensure that the gas spring threads match the end fitting thread.

6mm X 15mm gas springs, and 8mm X 18mm gas springs have M6 X 1 Threads.

10mm X 22mm gas springs have M8 X 1.25 Threads.

GSBL Adjusta-Lock Gas Springs

The new *GSBL Adjusta-Lock* is a stepped variably fixed gas spring which allows the spring to be fixed at any position in both the extended and compressed directions depending on the design. This is made possible by a valve integrated into the piston which separates both internal gas chambers. If the valve is closed interrupting the flow of gas between chambers the Adjusta-Lock spring is locked in that position. The valve is operated externally via a cable, handle or pulley, which are sold separately.

Below are accessories for the *Adjusta-Lock* Gas Spring. The BL-300 Hydraulic Release Assembly can be ordered with the cable length needed for your particular application.

Adjusta-Lock Gas Springs can be used for office chair, hospital bed and stretchers.

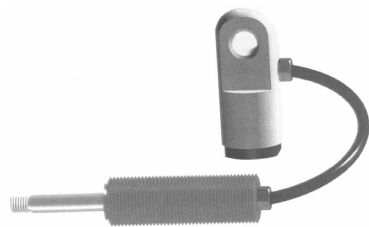
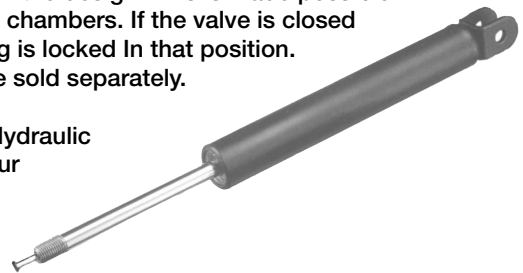

BL-300
Hydraulic
Release
Assembly



BL-400
Handle
Release
Assembly

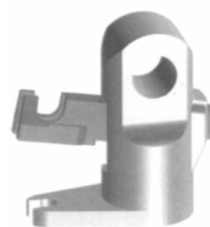

BL-100
Cable
Release
Head



BL-200
Cable
Release
Head

The *GSBL Adjusta-Lock* gas springs are a special order item designed to your specifications. Let our experienced *Gas Spring Engineering Department* help you design in the perfect spring for your product application!

SPD Dampers can be used anywhere a lid or weight must be lowered or moved in a controlled motion at a constant speed. There are three types of dampers, extension, compression, and dual. Extension Dampers provide controlled speed while the rod is being extended out of the tube. Compression Dampers provide a controlled speed while the rod is being compressed back into the tube. Dual dampers provide controlled speed in both directions.

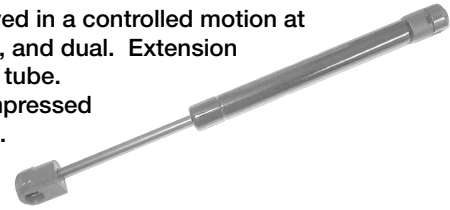

PART NUMBERS

Catalog Number	Rod Diameter (D)		Tube O.D.		Stroke (S)		"Base Cylinder Length (BL)"		Thread	Dampening Rate
	in	mm	in	mm	in	mm	in	mm	PS006 6mm thread	in/sec 40lbs Applied Load
DA-200A-CC	0.236	6.0	0.591	15.0	2.0	50.8	6.47	164	M6 x 1.0	1.40
DA-200A-CJ									M6 x 1.0	1.70
DA-200A-CD									M6 x 1.0	2.30
DA-200A-CN									M6 x 1.0	3.20
DA-200A-CE									M6 x 1.0	3.80
DA-200A-DC									M6 x 1.0	1.40
DA-200A-DJ									M6 x 1.0	1.70
DA-200A-DD									M6 x 1.0	2.30
DA-200A-DN									M6 x 1.0	3.20
DA-200A-DE									M6 x 1.0	3.80
DA-200A-EC									M6 x 1.0	2.30
DA-200A-EJ									M6 x 1.0	2.70
DA-200A-ED									M6 x 1.0	3.70
DA-200A-EN									M6 x 1.0	4.90
DA-200A-EE									M6 x 1.0	6.00
DA-300A-CC	0.236	6.0	0.591	15.0	3.0	76.2	8.60	218	M6 x 1.0	1.40
DA-300A-CJ									M6 x 1.0	1.70
DA-300A-CD									M6 x 1.0	2.30
DA-300A-CN									M6 x 1.0	3.20
DA-300A-CE									M6 x 1.0	3.80
DA-300A-DC									M6 x 1.0	1.40
DA-300A-DJ									M6 x 1.0	1.70
DA-300A-DD									M6 x 1.0	2.30
DA-300A-DN									M6 x 1.0	3.20
DA-300A-DE									M6 x 1.0	3.80
DA-300A-EC									M6 x 1.0	2.30
DA-300A-EJ									M6 x 1.0	2.70
DA-300A-ED									M6 x 1.0	3.70
DA-300A-EN									M6 x 1.0	4.90
DA-300A-EE									M6 x 1.0	6.00
DA-400A-CC	0.236	6.0	0.591	15.0	4.0	101.6	11.08	281	M6 x 1.0	1.40
DA-400A-CJ									M6 x 1.0	1.70
DA-400A-CD									M6 x 1.0	2.30
DA-400A-CN									M6 x 1.0	3.20
DA-400A-CE									M6 x 1.0	3.80
DA-400A-DC									M6 x 1.0	1.40
DA-400A-DJ									M6 x 1.0	1.70
DA-400A-DD									M6 x 1.0	2.30
DA-400A-DN									M6 x 1.0	3.20

Standard Dampers

Catalog Number	Rod Diameter (D)		Tube O.D.		Stroke (S)		"Base Cylinder Length (BL)"		Thread	Dampening Rate
	in	mm	in	mm	in	mm	in	mm	PS006 6mm thread	in/sec 40lbs Applied Load
DA-400A-DE	0.236	6.0	0.591	15.0	4.0	101.6	11.08	281	M6 x 1.0	3.80
DA-400A-EC									M6 x 1.0	2.30
DA-400A-EJ									M6 x 1.0	2.70
DA-400A-ED									M6 x 1.0	3.70
DA-400A-EN									M6 x 1.0	4.90
DA-400A-EE									M6 x 1.0	6.00
DA-500A-CC	0.236	6.0	0.591	15.0	5.0	127.0	13.60	345	M6 x 1.0	1.40
DA-500A-CJ									M6 x 1.0	1.70
DA-500A-CD									M6 x 1.0	2.30
DA-500A-CN									M6 x 1.0	3.20
DA-500A-CE									M6 x 1.0	3.80
DA-500A-DC									M6 x 1.0	1.40
DA-500A-DJ									M6 x 1.0	1.70
DA-500A-DD									M6 x 1.0	2.30
DA-500A-DN									M6 x 1.0	3.20
DA-500A-DE									M6 x 1.0	3.80
DA-500A-EC									M6 x 1.0	2.30
DA-500A-EJ									M6 x 1.0	2.70
DA-500A-ED									M6 x 1.0	3.70
DA-500A-EN									M6 x 1.0	4.90
DA-500A-EE									M6 x 1.0	6.00
DA-400V-CJ									0.315	8.0
DA-400V-CD	M6 x 1.0	0.60								
DA-400V-CE	M6 x 1.0	0.80								
DA-400V-CF	M6 x 1.0	1.00								
DA-400V-CS	M6 x 1.0	1.40								
DA-400V-DJ	M6 x 1.0	0.40								
DA-400V-DD	M6 x 1.0	0.60								
DA-400V-DE	M6 x 1.0	0.80								
DA-400V-DF	M6 x 1.0	1.00								
DA-400V-DS	M6 x 1.0	1.40								
DA-400V-EJ	M6 x 1.0	0.50								
DA-400V-ED	M6 x 1.0	0.70								
DA-400V-EE	M6 x 1.0	1.00								
DA-400V-EF	M6 x 1.0	1.30								
DA-400V-ES	M6 x 1.0	1.60								
DA-500V-CJ	0.315	8.0	0.709	18.0	5.0	127.0	13.07	332		
DA-500V-CD									M6 x 1.0	0.60
DA-500V-CE									M6 x 1.0	0.80
DA-500V-CF									M6 x 1.0	1.00
DA-500V-CS									M6 x 1.0	1.40
DA-500V-DJ									M6 x 1.0	0.40
DA-500V-DD									M6 x 1.0	0.60
DA-500V-DE									M6 x 1.0	0.80

Catalog Number	Rod Diameter (D)		Tube O.D.		Stroke (S)		"Base Cylinder Length (BL)"		Thread	Dampening Rate in/sec 40lbs Applied Load
	in	mm	in	mm	in	mm	in	mm		
DA-500V-DF	0.315	8.0	0.709	18.0	5.0	127.0	13.07	332	M6 x 1.0	1.00
DA-500V-DS									M6 x 1.0	1.40
DA-500V-EJ									M6 x 1.0	0.50
DA-500V-ED									M6 x 1.0	0.70
DA-500V-EE									M6 x 1.0	1.00
DA-500V-EF									M6 x 1.0	1.30
DA-500V-ES									M6 x 1.0	1.60
DA-600V-CJ	0.315	8.0	0.709	18.0	6.0	152.4	15.59	396	M6 x 1.0	0.40
DA-600V-CD									M6 x 1.0	0.60
DA-600V-CE									M6 x 1.0	0.80
DA-600V-CF									M6 x 1.0	1.00
DA-600V-CS									M6 x 1.0	1.40
DA-600V-DJ									M6 x 1.0	0.40
DA-600V-DD									M6 x 1.0	0.60
DA-600V-DE									M6 x 1.0	0.80
DA-600V-DF									M6 x 1.0	1.00
DA-600V-DS									M6 x 1.0	1.40
DA-600V-EJ									M6 x 1.0	0.50
DA-600V-ED									M6 x 1.0	0.70
DA-600V-EE									M6 x 1.0	1.00
DA-600V-EF									M6 x 1.0	1.30
DA-600V-ES									M6 x 1.0	1.60
DA-700V-CJ	0.315	8.0	0.709	18.0	7.0	177.8	18.23	463	M6 x 1.0	0.40
DA-700V-CD									M6 x 1.0	0.60
DA-700V-CE									M6 x 1.0	0.80
DA-700V-CF									M6 x 1.0	1.00
DA-700V-CS									M6 x 1.0	1.40
DA-700V-DJ									M6 x 1.0	0.40
DA-700V-DD									M6 x 1.0	0.60
DA-700V-DE									M6 x 1.0	0.80
DA-700V-DF									M6 x 1.0	1.00
DA-700V-DS									M6 x 1.0	1.40
DA-700V-EJ									M6 x 1.0	0.50
DA-700V-ED									M6 x 1.0	0.70
DA-700V-EE									M6 x 1.0	1.00
DA-700V-EF									M6 x 1.0	1.30
DA-700V-ES									M6 x 1.0	1.60

Designation of the Part Numbering System: (example: DA-200A-CJ-KFT)

DA-200A-CJ-KFT

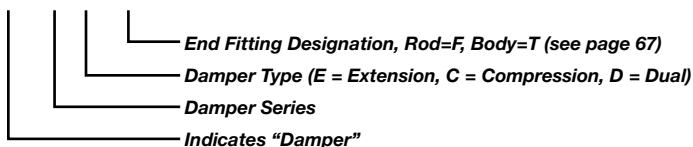

Please Note: Not all dampers listed are in stock. Lead times may apply. Dampers come standard with PS006 threaded ends, adding end fittings will change the part number!

Please see below and page 80-81 for instructions and complete details.

GSWB Welded Blade End Gas Springs

The "GSWB" Welded Blade End Gas Spring. This gas spring is a new addition to the SPD gas spring line that allows for a rigid mounting system to accommodate tight spacing. The welded blade is constructed of steel that includes a thru hole to be used with a pin or bolting system. It maintains the same nitrided shaft feature as the GSNI line to protect against possible corrosion in the application.

The GSWB series gas spring comes standard with the welded blade and thru hole diameter as identified in the below listed table. If an alternative end configuration is required please look at the GSNI series or contact engineering for assistance.



PART NUMBERS

Catalog Number	Rod Diameter (D)		Tube O.D.		Stroke (S)		Base Length (BL) Cylinder		Extended Length (L)		Force		End Fitting Rod	End Fitting Body
	in	mm	in	mm	in	mm	in	mm	in	mm	lbs	N		
GSWB-4106-11	0.236	6	0.591	15	0.79	20	3.15	80	4.17	106	11.2	50	Dia 6.1 mm Eye	Dia 6.1 mm Eye
GSWB-4106-22											22.5	100		
GSWB-4106-33											33.7	150		
GSWB-4106-45											45	200		
GSWB-4106-56											56.2	250		
GSWB-4106-67											67.4	300		
GSWB-4106-78											78.7	350		
GSWB-4146-11	0.236	6	0.591	15	1.57	40	4.72	120	5.75	146	11.2	50	Dia 6.1 mm Eye	Dia 6.1 mm Eye
GSWB-4146-22											22.5	100		
GSWB-4146-33											33.7	150		
GSWB-4146-45											45	200		
GSWB-4146-56											56.2	250		
GSWB-4146-67											67.4	300		
GSWB-4146-78											78.7	350		
GSWB-4165-11	0.236	6	0.591	15	1.60	41	5.48	139	6.50	165	11.2	50	Dia 6.1 mm Eye	Dia 6.1 mm Eye
GSWB-4165-22											22.5	100		
GSWB-4165-33											33.7	150		
GSWB-4165-45											45	200		
GSWB-4165-56											56.2	250		
GSWB-4165-67											67.4	300		
GSWB-4165-78											78.7	350		
GSWB-4186-11	0.236	6	0.591	15	2.36	60	6.30	160	7.32	186	11.2	50	Dia 6.1 mm Eye	Dia 6.1 mm Eye
GSWB-4186-22											22.5	100		
GSWB-4186-33											33.7	150		
GSWB-4186-45											45	200		
GSWB-4186-56											56.2	250		
GSWB-4186-67											67.4	300		
GSWB-4186-78											78.7	350		
GSWB-2206-22	0.315	8	0.709	18	2.36	60	6.93	176	8.11	206	22.5	100	Dia 8.1mm Eye	Dia 8.1mm Eye
GSWB-2206-33											33.7	150		
GSWB-2206-45											45	200		
GSWB-2206-56											56.2	250		
GSWB-2206-67											67.4	300		
GSWB-2206-78											78.7	350		
GSWB-2206-89											89.9	400		
GSWB-2206-101											101.2	450		
GSWB-2206-112											112.4	500		
GSWB-2206-123											123.7	550		
GSWB-2206-134											134.9	600		
GSWB-2206-146											146.1	650		

GSWB Welded Blade End Gas Springs

Catalog Number	Rod Diameter (D)		Tube O.D.		Stroke (S)		Base Length (BL)Cylinder		Extended Length (L)		Force		End Fitting Rod	End Fitting Body
	in	mm	in	mm	in	mm	in	mm	in	mm	lbs	N		
GSWB-4226-11	0.236	6	0.591	15	3.15	80	7.87	200	8.90	226	11.2	50	Dia 6.1 mm Eye	Dia 6.1 mm Eye
GSWB-4226-22											22.5	100		
GSWB-4226-33											33.7	150		
GSWB-4226-45											45	200		
GSWB-4226-56											56.2	250		
GSWB-4226-67											67.4	300		
GSWB-4226-78											78.7	350		
GSWB-2246-22	0.315	8	0.709	18	3.15	80	8.51	216	9.69	246	22.5	100	Dia 8.1mm Eye	Dia 8.1mm Eye
GSWB-2246-33											33.7	150		
GSWB-2246-45											45	200		
GSWB-2246-56											56.2	250		
GSWB-2246-67											67.4	300		
GSWB-2246-78											78.7	350		
GSWB-2246-89											89.9	400		
GSWB-2246-101											101.2	450		
GSWB-2246-112											112.4	500		
GSWB-2246-123											123.7	550		
GSWB-2246-134											134.9	600		
GSWB-2246-146											146.1	650		
GSWB-2254-22											0.315	8		
GSWB-2254-33	33.7	150												
GSWB-2254-45	45	200												
GSWB-2254-56	56.2	250												
GSWB-2254-67	67.4	300												
GSWB-2254-78	78.7	350												
GSWB-2254-89	89.9	400												
GSWB-2254-101	101.2	450												
GSWB-2254-112	112.4	500												
GSWB-2254-123	123.7	550												
GSWB-2254-134	134.9	600												
GSWB-2254-146	146.1	650												
GSWB-4264-11	0.236	6	0.591	15	3.94	100	9.37	238	10.39	264			11.2	50
GSWB-4264-22											22.5	100		
GSWB-4264-33											33.7	150		
GSWB-4264-45											45	200		
GSWB-4264-56											56.2	250		
GSWB-4264-67											67.4	300		
GSWB-4264-78											78.7	350		
GSWB-2286-22	0.315	8	0.709	18	3.94	100	10.08	256	11.26	286	22.5	100	Dia 8.1mm Eye	Dia 8.1mm Eye
GSWB-2286-33											33.7	150		
GSWB-2286-45											45	200		
GSWB-2286-56											56.2	250		
GSWB-2286-67											67.4	300		
GSWB-2286-78											78.7	350		
GSWB-2286-89											89.9	400		
GSWB-2286-101											101.2	450		
GSWB-2286-112											112.4	500		
GSWB-2286-123											123.7	550		
GSWB-2286-134											134.9	600		
GSWB-2286-146											146.1	650		

Catalog Number	Rod Diameter (D)		Tube O.D.		Stroke (S)		Base Length (BL)Cylinder		Extended Length (L)		Force		End Fitting Rod	End Fitting Body												
	in	mm	in	mm	in	mm	in	mm	in	mm	lbs	N														
GSWB-3286-33	0.394	10	0.866	22/23	3.74	95	10.08	256	11.26	286	33.7	150	Dia 8.1mm Eye	Dia 8.1mm Eye												
GSWB-3286-45											45	200														
GSWB-3286-56											56.2	250														
GSWB-3286-67											67.4	300														
GSWB-3286-78											78.7	350														
GSWB-3286-89											89.9	400														
GSWB-3286-101											101.2	450														
GSWB-3286-112											112.4	500														
GSWB-3286-123											123.7	550														
GSWB-3286-134											134.9	600														
GSWB-3286-146											146.1	650														
GSWB-3286-157											157.4	700														
GSWB-3286-168											168.6	750														
GSWB-3286-179											179.8	800														
GSWB-4305-11											0.236	6			0.591	15	4.72	120	10.99	279	12.01	305	11.2	50	Dia 6.1 mm Eye	Dia 6.1 mm Eye
GSWB-4305-22	22.5	100																								
GSWB-4305-33	33.7	150																								
GSWB-4305-45	45	200																								
GSWB-4305-56	56.2	250																								
GSWB-4305-67	67.4	300																								
GSWB-4305-78	78.7	350																								
GSWB-2326-22	0.315	8	0.709	18	4.72	120	11.68	296	12.83	326	22.5	100	Dia 8.1mm Eye	Dia 8.1mm Eye												
GSWB-2326-33											33.7	150														
GSWB-2326-45											45	200														
GSWB-2326-56											56.2	250														
GSWB-2326-67											67.4	300														
GSWB-2326-78											78.7	350														
GSWB-2326-89											89.9	400														
GSWB-2326-101											101.2	450														
GSWB-2326-112											112.4	500														
GSWB-2326-123											123.7	550														
GSWB-2326-134											134.9	600														
GSWB-2326-146											146.1	650														
GSWB-4366-11											0.236	6			0.591	15	5.91	150	13.39	340	14.41	366	11.2	50	Dia 6.1 mm Eye	Dia 6.1 mm Eye
GSWB-4366-22																							22.5	100		
GSWB-4366-33																							33.7	150		
GSWB-4366-45	45	200																								
GSWB-4366-56	56.2	250																								
GSWB-4366-67	67.4	300																								
GSWB-4366-78	78.7	350																								

GSWB Welded Blade End Gas Springs

Catalog Number	Rod Diameter (D)		Tube O.D.		Stroke (S)		Base Length (BL) Cylinder		Extended Length (L)		Force		End Fitting Rod	End Fitting Body
	in	mm	in	mm	in	mm	in	mm	in	mm	lbs	N		
GSWB-2366-22	0.315	8	0.709	18	5.51	140	13.39	340	14.41	366	22.5	100	Dia 8.1mm Eye	Dia 8.1mm Eye
GSWB-2366-33											33.7	150		
GSWB-2366-45											45	200		
GSWB-2366-56											56.2	250		
GSWB-2366-67											67.4	300		
GSWB-2366-78											78.7	350		
GSWB-2366-89											89.9	400		
GSWB-2366-101											101.2	450		
GSWB-2366-112											112.4	500		
GSWB-2366-123											123.7	550		
GSWB-2366-134											134.9	600		
GSWB-2366-146											146.1	650		
GSWB-2380-22											0.315	8		
GSWB-2380-33	33.7	150												
GSWB-2380-45	45	200												
GSWB-2380-56	56.2	250												
GSWB-2380-67	67.4	300												
GSWB-2380-78	78.7	350												
GSWB-2380-89	89.9	400												
GSWB-2380-101	101.2	450												
GSWB-2380-112	112.4	500												
GSWB-2380-123	123.7	550												
GSWB-2380-134	134.9	600												
GSWB-2380-146	146.1	650												
GSWB-3385-33	0.394	10	0.866	22/23	5.91	150	13.98	355	15.16	385			33.7	150
GSWB-3385-45											45	200		
GSWB-3385-56											56.2	250		
GSWB-3385-67											67.4	300		
GSWB-3385-78											78.7	350		
GSWB-3385-89											89.9	400		
GSWB-3385-101											101.2	450		
GSWB-3385-112											112.4	500		
GSWB-3385-123											123.7	550		
GSWB-3385-134											134.9	600		
GSWB-3385-146											146.1	650		
GSWB-3385-157											157.4	700		
GSWB-3385-168											168.6	750		
GSWB-3385-179	179.8	800												
GSWB-2409-22	0.315	8	0.709	18	6.3	160	14.92	379	16.1	409	22.5	100	Dia 8.1mm Eye	Dia 8.1mm Eye
GSWB-2409-33											33.7	150		
GSWB-2409-45											45	200		
GSWB-2409-56											56.2	250		
GSWB-2409-67											67.4	300		
GSWB-2409-78											78.7	350		
GSWB-2409-89											89.9	400		
GSWB-2409-101											101.2	450		
GSWB-2409-112											112.4	500		
GSWB-2409-123											123.7	550		
GSWB-2409-134											134.9	600		
GSWB-2409-146											146.1	650		

GSWB Welded Blade End Gas Springs

Catalog Number	Rod Diameter (D)		Tube O.D.		Stroke (S)		Base Length (BL) Cylinder		Extended Length (L)		Force		End Fitting Rod	End Fitting Body
	in	mm	in	mm	in	mm	in	mm	in	mm	lbs	N		
GSWB-2447-22	0.315	8	0.709	18	7.09	180	16.42	417	17.6	447	22.5	100	Dia 8.1mm Eye	Dia 8.1mm Eye
GSWB-2447-33											33.7	150		
GSWB-2447-45											45	200		
GSWB-2447-56											56.2	250		
GSWB-2447-67											67.4	300		
GSWB-2447-78											78.7	350		
GSWB-2447-89											89.9	400		
GSWB-2447-101											101.2	450		
GSWB-2447-112											112.4	500		
GSWB-2447-123											123.7	550		
GSWB-2447-134											134.9	600		
GSWB-2447-146											146.1	650		
GSWB-2486-22											0.315	8		
GSWB-2486-33	33.7	150												
GSWB-2486-45	45	200												
GSWB-2486-56	56.2	250												
GSWB-2486-67	67.4	300												
GSWB-2486-78	78.7	350												
GSWB-2486-89	89.9	400												
GSWB-2486-101	101.2	450												
GSWB-2486-112	112.4	500												
GSWB-2486-123	123.7	550												
GSWB-2486-134	134.9	600												
GSWB-2486-146	146.1	650												
GSWB-3486-33	0.394	10	0.866	22/23	7.87	200	18.01	456	19.13	486			33.7	150
GSWB-3486-45											45	200		
GSWB-3486-56											56.2	250		
GSWB-3486-67											67.4	300		
GSWB-3486-78											78.7	350		
GSWB-3486-89											89.9	400		
GSWB-3486-101											101.2	450		
GSWB-3486-112											112.4	500		
GSWB-3486-123											123.7	550		
GSWB-3486-134											134.9	600		
GSWB-3486-146											146.1	650		
GSWB-3486-157											157.4	700		
GSWB-3486-168											168.6	750		
GSWB-3486-179	179.8	800												
GSWB-2508-22	0.315	8	0.709	18	8.39	213	18.82	478	20.0	508	22.5	100	Dia 8.1mm Eye	Dia 8.1mm Eye
GSWB-2508-33											33.7	150		
GSWB-2508-45											45	200		
GSWB-2508-56											56.2	250		
GSWB-2508-67											67.4	300		
GSWB-2508-78											78.7	350		
GSWB-2508-89											89.9	400		
GSWB-2508-101											101.2	450		
GSWB-2508-112											112.4	500		
GSWB-2508-123											123.7	550		
GSWB-2508-134											134.9	600		
GSWB-2508-146											146.1	650		

We reserve the right to add, delete or modify components without notification.
All dimensions are nominal unless tolerance is stated.

Catalog Number	Rod Diameter (D)		Tube O.D.		Stroke (S)		Base Length (BL)Cylinder		Extended Length (L)		Force		End Fitting Rod	End Fitting Body												
	in	mm	in	mm	in	mm	in	mm	in	mm	lbs	N														
GSWB-2526-22	0.315	8	0.709	18	8.66	220	19.53	496	20.71	526	22.5	100	Dia 8.1mm Eye	Dia 8.1mm Eye												
GSWB-2526-33											33.7	150														
GSWB-2526-45											45	200														
GSWB-2526-56											56.2	250														
GSWB-2526-67											67.4	300														
GSWB-2526-78											78.7	350														
GSWB-2526-89											89.9	400														
GSWB-2526-101											101.2	450														
GSWB-2526-112											112.4	500														
GSWB-2526-123											123.7	550														
GSWB-2526-134											134.9	600														
GSWB-2526-146											146.1	650														
GSWB-2586-22											0.315	8			0.709	18	9.84	250	21.89	556	23.07	586	22.5	100	Dia 8.1mm Eye	Dia 8.1mm Eye
GSWB-2586-33																							33.7	150		
GSWB-2586-45	45	200																								
GSWB-2586-56	56.2	250																								
GSWB-2586-67	67.4	300																								
GSWB-2586-78	78.7	350																								
GSWB-2586-89	89.9	400																								
GSWB-2586-101	101.2	450																								
GSWB-2586-112	112.4	500																								
GSWB-2586-123	123.7	550																								
GSWB-2586-134	134.9	600																								
GSWB-2586-146	146.1	650																								
GSWB-3586-33	0.394	10	0.866	22/23	9.84	250	21.89	556	23.07	586			33.7	150									Dia 8.1mm Eye	Dia 8.1mm Eye		
GSWB-3586-45													45	200												
GSWB-3586-56											56.2	250														
GSWB-3586-67											67.4	300														
GSWB-3586-78											78.7	350														
GSWB-3586-89											89.9	400														
GSWB-3586-101											101.2	450														
GSWB-3586-112											112.4	500														
GSWB-3586-123											123.7	550														
GSWB-3586-134											134.9	600														
GSWB-3586-146											146.1	650														
GSWB-3586-157											157.4	700														
GSWB-3586-168											168.6	750														
GSWB-3586-179											179.8	800														

GSWB Welded Blade End Gas Springs

Catalog Number	Rod Diameter (D)		Tube O.D.		Stroke (S)		Base Length (BL) Cylinder		Extended Length (L)		Force		End Fitting Rod	End Fitting Body
	in	mm	in	mm	in	mm	in	mm	in	mm	lbs	N		
GSWB-3685-33	0.394	10	0.866	22/23	11.81	300	25.79	655	26.97	685	33.7	150	Dia 8.1mm Eye	Dia 8.1mm Eye
GSWB-3685-45											45	200		
GSWB-3685-56											56.2	250		
GSWB-3685-67											67.4	300		
GSWB-3685-78											78.7	350		
GSWB-3685-89											89.9	400		
GSWB-3685-101											101.2	450		
GSWB-3685-112											112.4	500		
GSWB-3685-123											123.7	550		
GSWB-3685-134											134.9	600		
GSWB-3685-146											146.1	650		
GSWB-3685-157											157.4	700		
GSWB-3685-168											168.6	750		
GSWB-3685-179											179.8	800		
GSWB-3785-33	0.394	10	0.866	22/23	13.78	350	29.72	755	30.91	785	33.7	150	Dia 8.1mm Eye	Dia 8.1mm Eye
GSWB-3785-45											45	200		
GSWB-3785-56											56.2	250		
GSWB-3785-67											67.4	300		
GSWB-3785-78											78.7	350		
GSWB-3785-89											89.9	400		
GSWB-3785-101											101.2	450		
GSWB-3785-112											112.4	500		
GSWB-3785-123											123.7	550		
GSWB-3785-134											134.9	600		
GSWB-3785-146											146.1	650		
GSWB-3785-157											157.4	700		
GSWB-3785-168											168.6	750		
GSWB-3785-179											179.8	800		

The "TSNI" Traction Gas Spring. This gas spring compliments the existing offering from SPD by giving its customers the ability to operate in traction rather than in compression. Traction springs are great for systems where a tensional load, similar to an extension spring, needs to be applied to hold a system open or hold a lid closed. The rod maintains a nitrided surface that complements the black painted body similar to the standard GSNI series of springs.

The TSNI series gas spring comes standard with 13mm ball sockets, part number EF-PS100BP. This end can be used in coordination with a stand alone 13mm stud or with a pre-assembled 13mm stud bracket combination. Please contact engineering for any assistance with these systems.



Catalog Number	Rod Diameter (D)		Tube O.D.		Stroke (S)		Base Length (BL)Cylinder		Extended Length (L)		Force		End Fitting	Thread										
	in	mm	in	mm	in	mm	in	mm	in	mm	lbs	N												
TSNI-0050-0100	0.394	10.0	1.060	27.0	1.97	50	5.90	150	10.24	260	22.5	100	EF-PS100BP	M8 x 1.25										
TSNI-0050-0150											33.7	150	EF-PS100BP	M8 x 1.25										
TSNI-0050-0200											44.9	200	EF-PS100BP	M8 x 1.25										
TSNI-0050-0250											56.2	250	EF-PS100BP	M8 x 1.25										
TSNI-0050-0300											67.4	300	EF-PS100BP	M8 x 1.25										
TSNI-0050-0350											78.7	350	EF-PS100BP	M8 x 1.25										
TSNI-0050-0400											89.9	400	EF-PS100BP	M8 x 1.25										
TSNI-0100-0100	0.394	10.0	1.060	27.0	3.94	100	7.87	200	14.17	360	22.5	100	EF-PS100BP	M8 x 1.25										
TSNI-0100-0150											33.7	150	EF-PS100BP	M8 x 1.25										
TSNI-0100-0200											44.9	200	EF-PS100BP	M8 x 1.25										
TSNI-0100-0250											56.2	250	EF-PS100BP	M8 x 1.25										
TSNI-0100-0300											67.4	300	EF-PS100BP	M8 x 1.25										
TSNI-0100-0350											78.7	350	EF-PS100BP	M8 x 1.25										
TSNI-0100-0400											89.9	400	EF-PS100BP	M8 x 1.25										
TSNI-0150-0100	0.394	10.0	1.060	27.0	5.91	150	9.84	249	18.11	460	22.5	100	EF-PS100BP	M8 x 1.25										
TSNI-0150-0150											33.7	150	EF-PS100BP	M8 x 1.25										
TSNI-0150-0200											44.9	200	EF-PS100BP	M8 x 1.25										
TSNI-0150-0250											56.2	250	EF-PS100BP	M8 x 1.25										
TSNI-0150-0300											67.4	300	EF-PS100BP	M8 x 1.25										
TSNI-0150-0350											78.7	350	EF-PS100BP	M8 x 1.25										
TSNI-0150-0400											89.9	400	EF-PS100BP	M8 x 1.25										
TSNI-0200-0100	0.394	10.0	1.060	27.0	7.87	200	11.81	300	22.05	560	22.5	100	EF-PS100BP	M8 x 1.25										
TSNI-0200-0150											33.7	150	EF-PS100BP	M8 x 1.25										
TSNI-0200-0200											44.9	200	EF-PS100BP	M8 x 1.25										
TSNI-0200-0250											56.2	250	EF-PS100BP	M8 x 1.25										
TSNI-0200-0300											67.4	300	EF-PS100BP	M8 x 1.25										
TSNI-0200-0350											78.7	350	EF-PS100BP	M8 x 1.25										
TSNI-0200-0400											89.9	400	EF-PS100BP	M8 x 1.25										
TSNI-0250-0100	0.394	10.0	1.060	27.0	9.84	250	13.78	349	25.98	660	22.5	100	EF-PS100BP	M8 x 1.25										
TSNI-0250-0150											33.7	150	EF-PS100BP	M8 x 1.25										
TSNI-0250-0200											44.9	200	EF-PS100BP	M8 x 1.25										
TSNI-0250-0250											56.2	250	EF-PS100BP	M8 x 1.25										
TSNI-0250-0300											67.4	300	EF-PS100BP	M8 x 1.25										
TSNI-0250-0350											78.7	350	EF-PS100BP	M8 x 1.25										
TSNI-0250-0400											89.9	400	EF-PS100BP	M8 x 1.25										
TSNI-0250-0450											101.2	450	EF-PS100BP	M8 x 1.25										
TSNI-0250-0500											112.4	500	EF-PS100BP	M8 x 1.25										
TSNI-0250-0550											123.7	550	EF-PS100BP	M8 x 1.25										
TSNI-0250-0600											134.9	600	EF-PS100BP	M8 x 1.25										
TSNI-0250-0650											146.1	650	EF-PS100BP	M8 x 1.25										
TSNI-0300-0100											0.394	10.0	1.060	27.0	11.81	300	15.75	400	29.92	760	22.5	100	EF-PS100BP	M8 x 1.25
TSNI-0300-0150																					33.7	150	EF-PS100BP	M8 x 1.25
TSNI-0300-0200	44.9	200	EF-PS100BP	M8 x 1.25																				
TSNI-0300-0250	56.2	250	EF-PS100BP	M8 x 1.25																				
TSNI-0300-0300	67.4	300	EF-PS100BP	M8 x 1.25																				
TSNI-0300-0350	78.7	350	EF-PS100BP	M8 x 1.25																				
TSNI-0300-0400	89.9	400	EF-PS100BP	M8 x 1.25																				

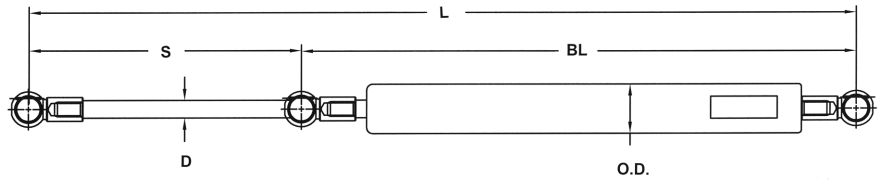

All Other Gas Springs

For our GSNI, GSSX, GSEL, GSVL, Dampers and GSWB Series

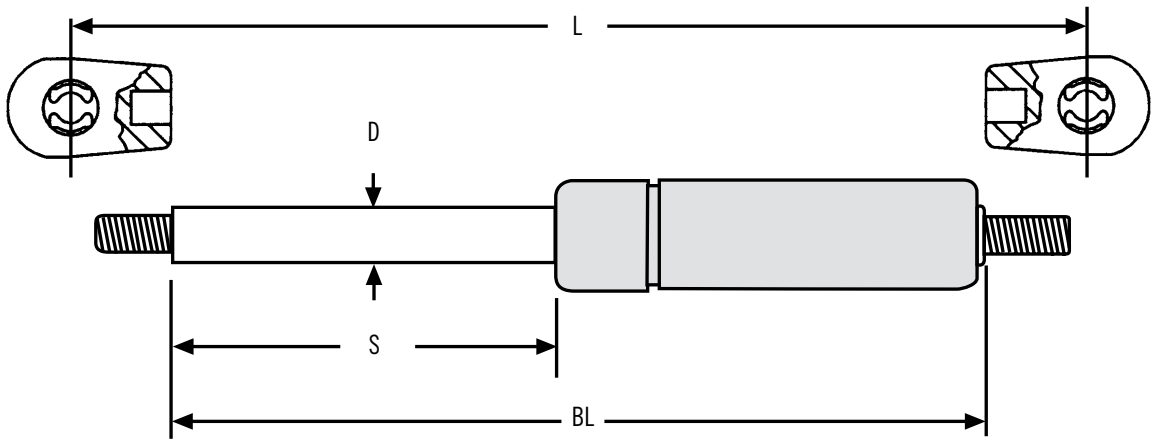

Part Number	Material	Code
EF-PS30B1	Composite, Nitrided Retainer	A
EF-PS30G1	Gray Composite, Chrome Retainer	B

* For use with 10mm ball stud

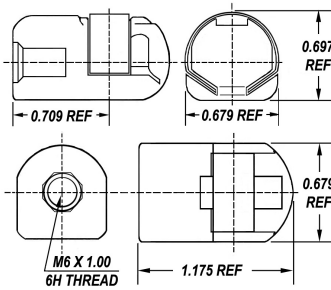

Part Number	Material	Code
EF-PS130	Composite With Snap On Cap	C

* For use with 10mm ball stud

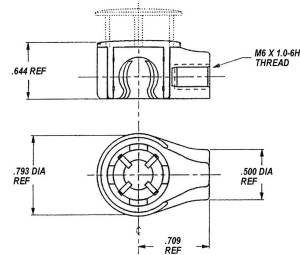

Part Number	Material	Code
EF-PS30B2	Composite With Black Steel Clip	D
EF-PS91	Steel Zinc Plate	E
EF-PS91-BP	Steel Black Nitrided Finish	F
EF-PS30B3	Composite with SST Clip	W

* For use with 10mm ball stud

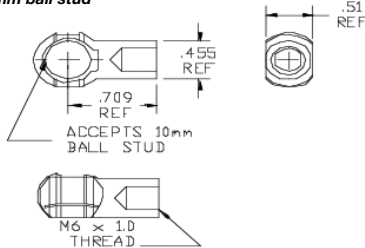

Part Number	Material	Code
EF-12778	Steel Zinc Plate	G

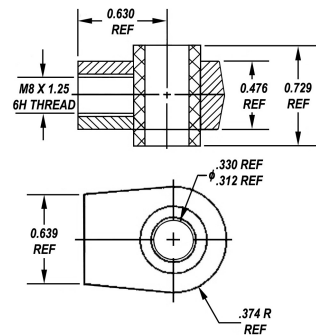

Part Number	Material	Code
EF-PS90	Steel Zinc Plate	H
EF-PS90-SS	Stainless Steel	I
EF-PS90BP	Steel Black Nitrided Finish	J

* For use with 10mm ball stud
* Must be used with SC-1006 safety clip

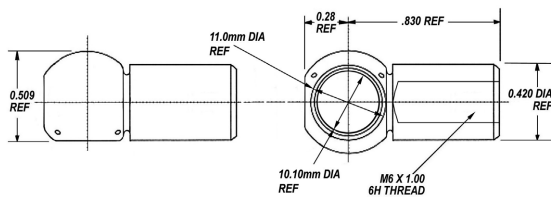

Part Number	Material	Code
EF-PS90M1	Steel Zinc Plate	L
EF-PS90M1-SS	Stainless Steel	M
EF-PS90M1BP	Steel Black Nitrided Finish	N

* For use with 10mm ball stud
* Must be used with SC-1006 safety clip

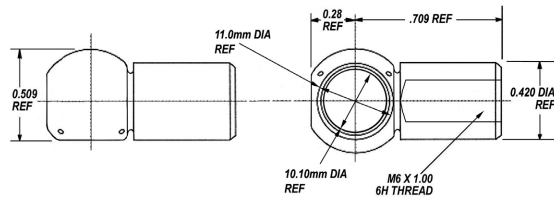

Part Number	Material	Code
EF-PS100	Steel Zinc Plate	O
EF-PS100-SS	Stainless Steel	P
EF-PS100BP	Steel Black Nitrided Finish	Q

* For 13mm ball stud
* Must be used with SC-1008 safety clip

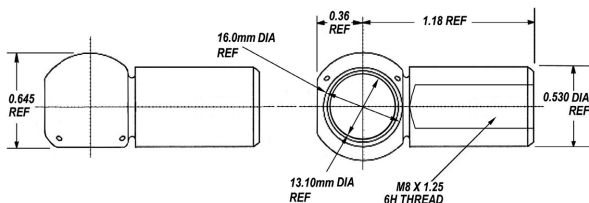

Part Number	Thru Hole Dia.	Material	Code
EF-PS120	.513"	Zinc Alloy	R
EF-PS121	.408"	Zinc Alloy	S
EF-PS122	.328"	Zinc Alloy	T
EF-PS123	.263"	Zinc Alloy	U
EF-PS124	.208"	Zinc Alloy	V

* For use with stud or thru-bolt mounting

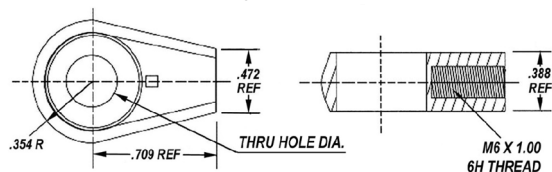

Part Number	Material
EF-13857	Steel Black Nitride

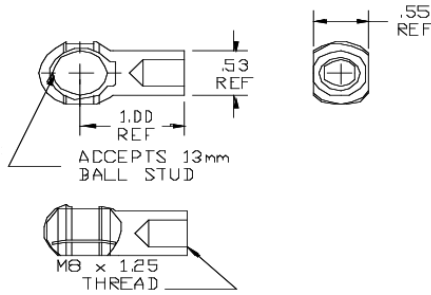

Part Number	Material
EF-13858	Steel Black Nitride

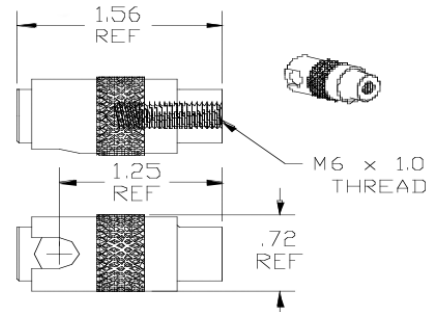

Part Number	Material
EF-13859	Black Nylon

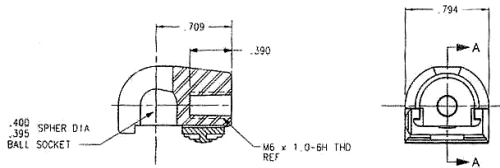

Part Number	Material
SC-1006*	Stainless Steel
SC-1008**	Stainless Steel
SC-1010***	Stainless Steel

* Must be used with EF-PS90 and EF-PS90M1 10mm end fitting
 ** Must be used with EF-PS100 13mm end fitting
 *** Must be used with EF-PS140 16mm end fitting

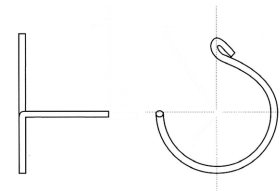

Part Number	"A"	"B"	"C"	Material
EF-13932	0.39"	1.18"	0.63"	316 SST
EF-13982	0.39"	1.40"	0.75"	304 SST

* For use with thru bolt or stud mounting

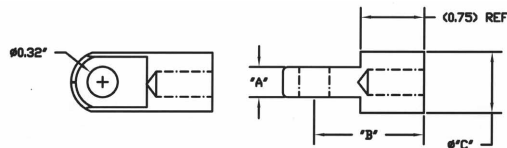

Part Number	Material
EF-PS140	Steel Zinc Plated
EF-PS140-SS	Stainless Steel
EF-PS140BP	Steel Black Nitrided Finish

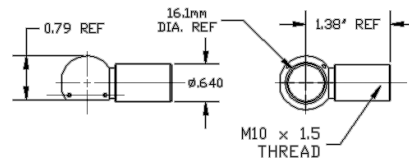

Rod End Bearings

Part Number	Material	A	B	C	D
FMP0120610RH	Steel Zinc Plate	1.18	0.433	0.236	M6 x 1.0
FMP0160812RH	Steel Zinc Plate	1.42	0.512	0.315	M8 x 1.25
FMP0201015RH	Steel Zinc Plate	1.69	0.669	0.394	M10 x 1.5
FMS0120610RH	Stainless Steel	1.18	0.433	0.236	M6 x 1.0
FMS0160812RH	Stainless Steel	1.42	0.512	0.315	M8 x 1.25
FMS0201015RH	Stainless Steel	1.69	0.669	0.394	M10 x 1.5

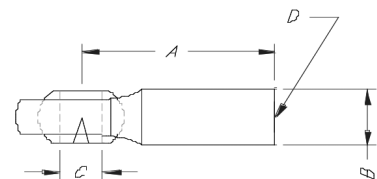

Part Number	Material
BS-1005	Steel Zinc Plate
BS-1005-SS	Stainless Steel
BS-1005-BZ	Black Zinc

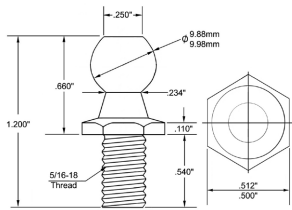

Part Number	Material
BS-1003	Steel Zinc Plate

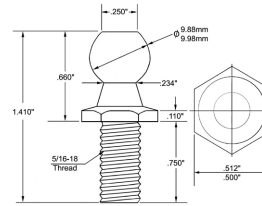

Part Number	Material
BS-1009	Steel Zinc Plate
BS-1009-SS	Stainless Steel

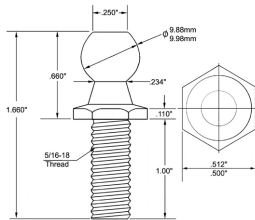

Part Number	Material
BS-1002	Steel Zinc Yellow Plate

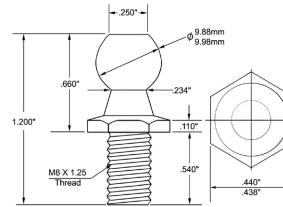

Part Number	Material
BS-1007	Steel Zinc Plate
BS-1007-SS	Stainless Steel
BS-1007-BP	Steel Black Powder Coat

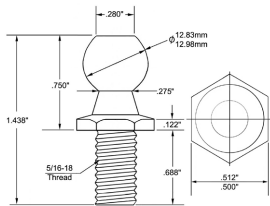

Part Number	Material
BS-11208	Steel Zinc Plate

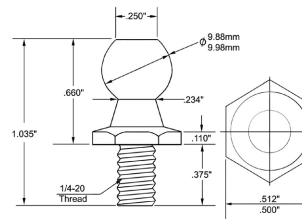

Part Number	Material
BS-1007L	Steel Zinc Plate

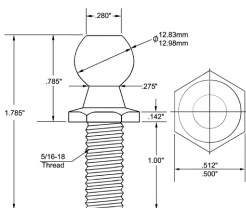

Part Number	Material
BS-1007MET	Steel Zinc Dichromate

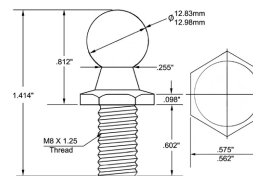

Part Number	Material
BS-1016	Steel Zinc Plate
BS-1016-SS	Stainless Steel

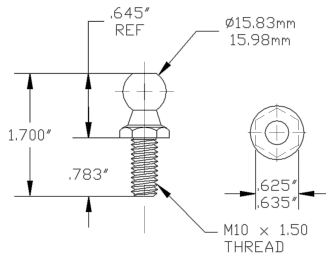

Part Number	Material
BS-1001W	Raw Steel

* Semi-tubular rivetable or weldable ball stud

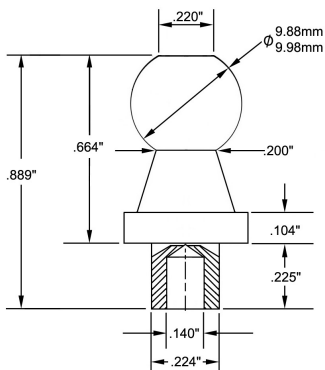

Part Number	Material
BS-1001	Steel Zinc Plate

* Semi-tubular rivetable ball stud

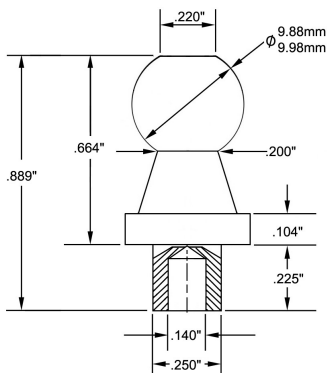

Part Number	Material
BS-1004W	Raw Steel

* Semi-tubular rivetable ball stud

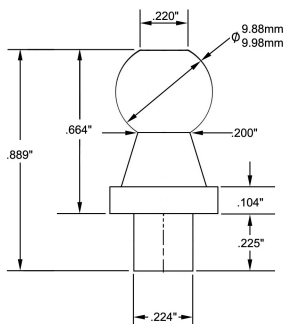

Part Number	Material
BS-1004	Steel Zinc Plate

* Solid rivetable ball stud

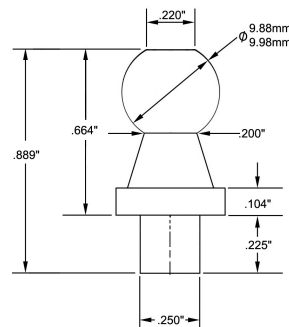

Part Number	Material
NU-1200	Steel Zinc Plate
NU-1200-SS	Stainless Steel

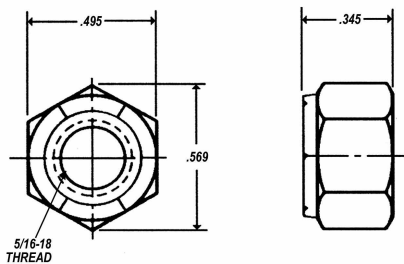

Part Number	Material
BR-1020	Steel Zinc Plate
BR-1020-BP	Black Powder Coat
BRX-1020	All Stainless Steel
BRX-1020-P	Electro Polished Stainless Steel

* 2mm thick material * .200 Dia. mounting holes
* 10mm ball stud

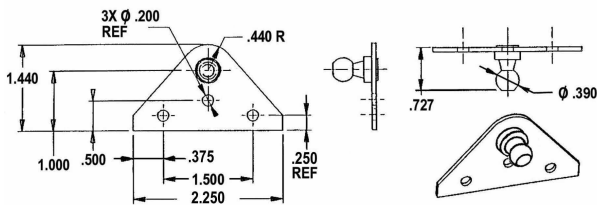

Part Number	Material
BR-1055	Steel Zinc Plate

* 3mm thick material * .272 Dia. mounting holes
* 10mm ball stud

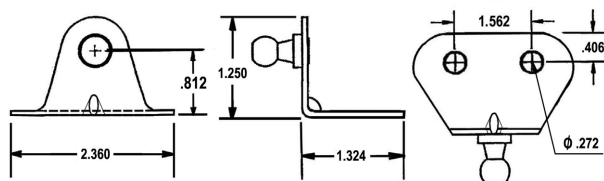

Part Number	Material
BR-1025	Steel Zinc Plate
BR-1025-BP	Black Powder Coat
BRX-1025	All Stainless Steel
BRX-1025-P	Electro Polished Stainless Steel

* 2.5mm thick material * 200 Dia. mounting holes
* 10mm ball stud

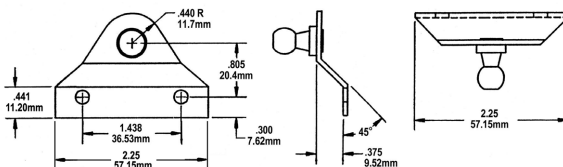

Part Number	Material
BR-1010	Steel Zinc Plate
BR-1010-BP	Black Powder Coat
BRX-1010	All Stainless Steel
BRX-1010-P	Electro Polished Stainless Steel

* 2mm thick material * .200 Dia. mounting holes
* 10mm ball stud

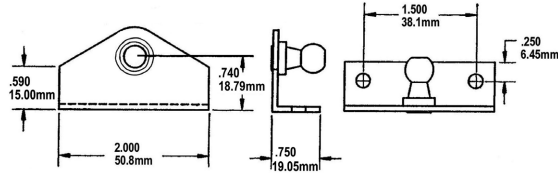

Part Number	Material
BR-1015	Steel Zinc Plate
BR-1015-BP	Black Powder Coat
BRX-1015	All Stainless Steel
BRX-1015-P	Electro Polished Stainless Steel

* 2mm thick material * .200 Dia. mounting holes
* 10mm ball stud

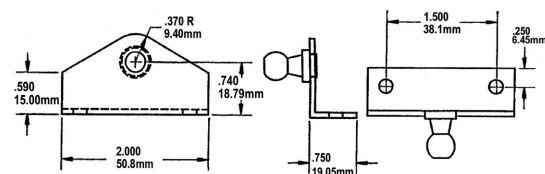

Part Number	Material
BR-1045	Steel Zinc Plate
BR-1045-BP	Black Powder Coat
BRX-1045	All Stainless Steel
BRX-13137	All Stainless Steel (13mm ball stud)
BRX-1045-P	Electro Polished Stainless Steel

* 3mm thick material * .200 Dia. mounting holes
* 10mm ball stud

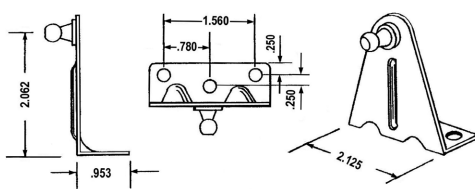

Part Number	Material
BR-1050	Steel Zinc Plate
BR-1050-BP	Black Powder Coat
BRX-1050	All Stainless Steel
BRX-1050-P	Electro Polished Stainless Steel

* 3mm thick material * .200 Dia. mounting holes
* 10mm ball stud

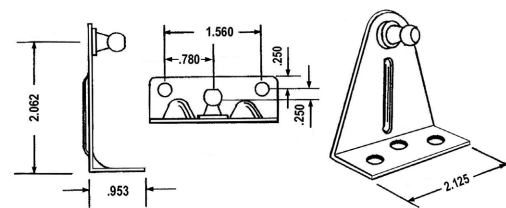

Part Number	Material
BR-1060	Steel Zinc Plate
BR-1060-BP	Black Powder Coat
BRX-1060	All Stainless Steel
BR-1060A	Aluminum
BRX-1060-P	Electro Polished Stainless Steel

* 3mm thick material * .200 Dia. mounting holes
* 10mm ball stud

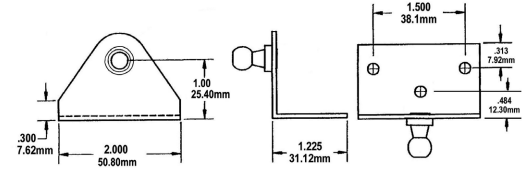

Part Number	Material
BR-1080	Steel Zinc Plate
BR-1080-BP	Black Powder Coat
BRX-1080	All Stainless Steel
BRX-1080-P	Electro Polished Stainless Steel
BR-13442**	Steel Zinc Plate

* 3mm thick material * .200 Dia. mounting holes
* 10mm ball stud ** 2x .290 mounting holes

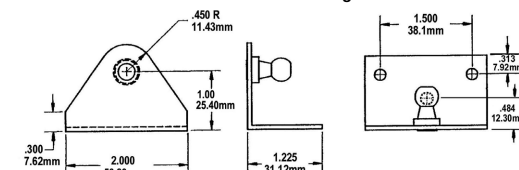

Part Number	Material
BR-1024	Steel Zinc Plate
BRX-1024	Stainless Steel Bracket
BRX-1024-P	Electro Polished Stainless Steel Bracket

* 2mm thick material * .200 Dia. mounting holes
* 10mm ball stud

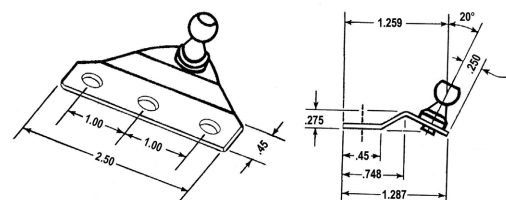

Part Number	Material
BR-12600	Steel Zinc Plate

* 2mm thick material * .200 Dia. mounting holes
* 10mm long ball stud

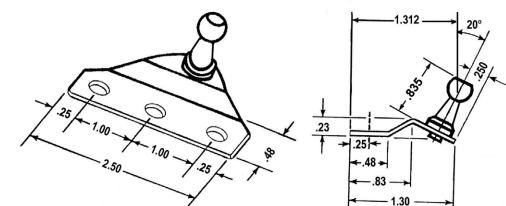

Part Number	Material
BR-1091	Steel Zinc Plate
BR-1091-BP	Black Powder Coat

* 2.5mm thick material * .188 Dia. mounting holes
* 10mm ball stud

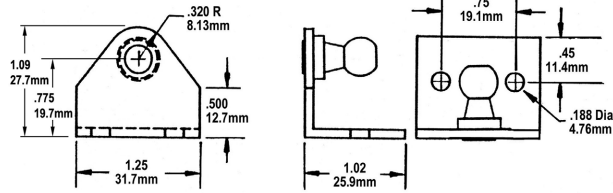

Part Number	Material
BR-1092	Steel Zinc Plate
BRX-1092	Stainless Steel Bracket

* 2.5mm thick material * .188 Dia. mounting holes
* 10mm ball stud

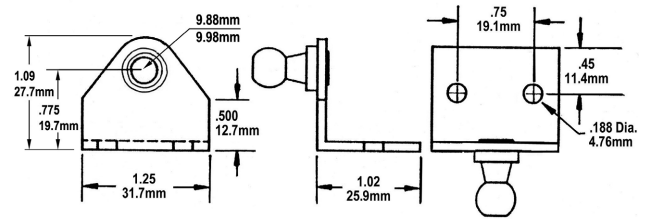

Part Number	Material
BR-1125	Steel Zinc Plate

* 3mm thick material * .203 Dia. mounting holes
* 10mm ball stud

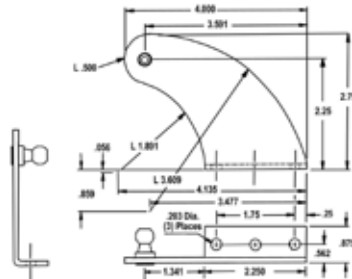

Part Number	Material
BR-1120	Steel Zinc Plate

* 3mm thick material * .203 Dia. mounting holes
* 10mm ball stud

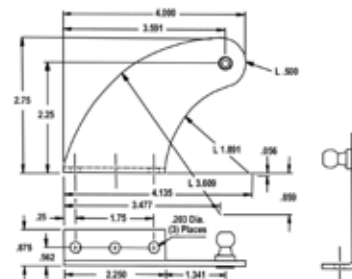

Part Number	Material
BR-1124-BP	Steel Black Powder Coat

* 3mm thick material * 10mm ball stud

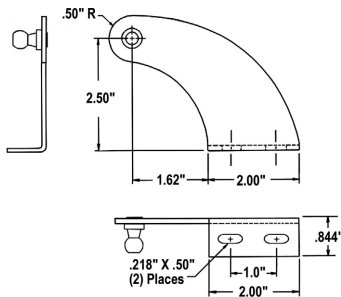

Part Number	Material
BR-1119-BP	Steel Black Powder Coat

* 3mm thick material * 10mm ball stud

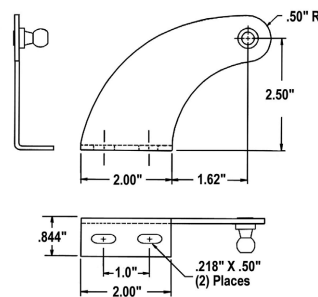

Part Number	Material
BR-1125-BP	Steel Black Powder Coat

* 3mm thick material * 10mm ball stud

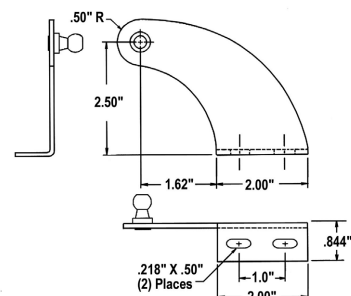

Part Number	Material
BR-1120-BP	Steel Black Powder Coat

* 3mm thick material * 10mm ball stud

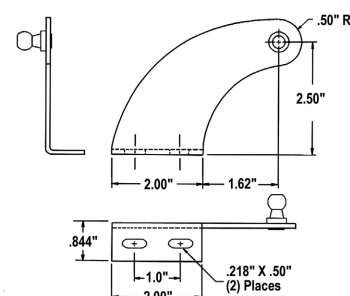

Part Number	Material
BR-1012	Steel Zinc Plate

* 2mm thick material * .200 Dia. mounting holes
* 10mm ball stud

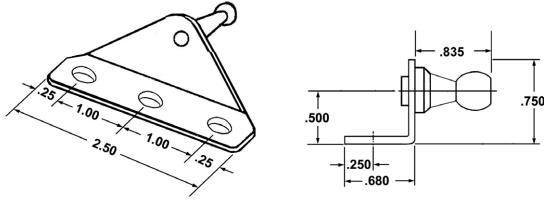

Part Number	Material
BR-12601	Steel Zinc Plate

* 2mm thick material * .200 Dia. mounting holes
* 10mm ball stud

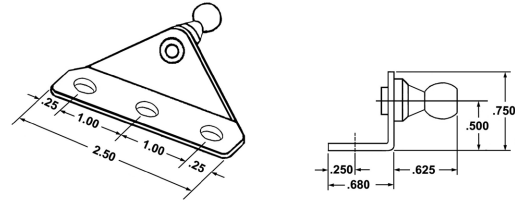

Part Number	Material
BR-12602	Steel Zinc Plate

* 3mm thick material * .200 Dia. mounting holes
* 10mm ball stud

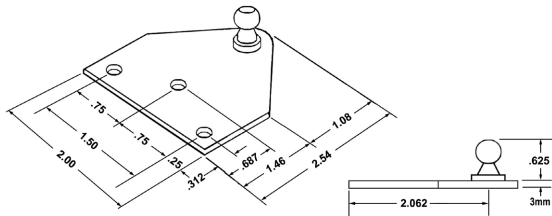

Part Number	Material
BR-1065	Steel Zinc Plate

* 3mm thick material * .200 Dia. mounting holes
* 10mm ball stud

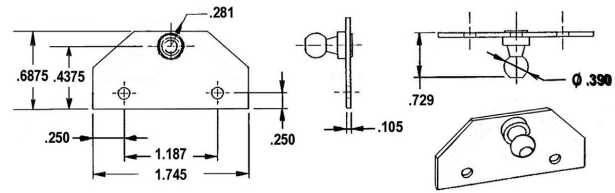

Part Number	Material
BR-1095	Steel Zinc Plate
BR-1095-BP	Black Powder Coat
BRX-1095	All Stainless Steel

* 2.5mm thick material * .200 Dia. mounting holes
* 10mm ball stud

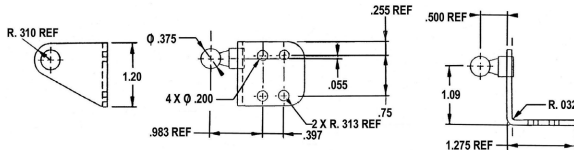

Part Number	Material
BR-1096	Steel Zinc Plate
BR-1096-BP	Black Powder Coat
BRX-1096	All Stainless Steel

* 2.5mm thick material * .200 Dia. mounting holes
* 10mm ball stud

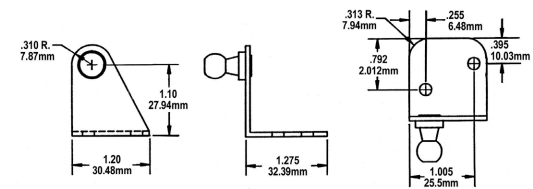

Part Number	Material
BR-1075	Steel Zinc Plate
BR-1075-BP	Black Powder Coat

* 2.5mm thick material * .200 Dia. mounting holes
* 10mm ball stud

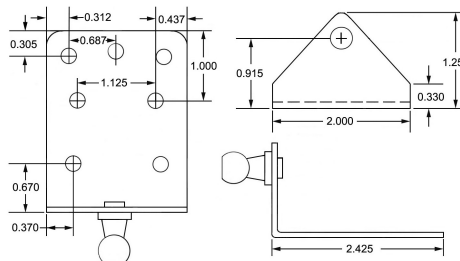

Part Number	Material
BR-12904	Steel Zinc Plate
BR-12904-BP	Black Powder Coat

* 2.5mm thick material * .200 Dia. mounting holes
* 10mm ball stud

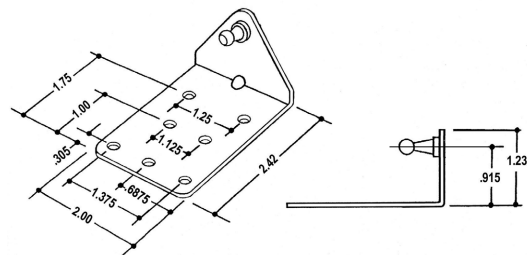

Part Number	Material
BR-1130	Steel Zinc Plate
BR-1130A	Aluminum

* 3mm thick material * .200 Dia. mounting holes
* 10mm ball stud

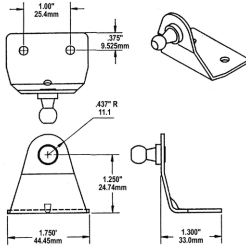

Part Number	Material
BR-1100	Steel Zinc Plate
BR-1100-BP	Black Powder Coat
BRX-1100	All Stainless Steel

* 3mm thick material * .200 Dia. mounting holes
* 10mm ball stud

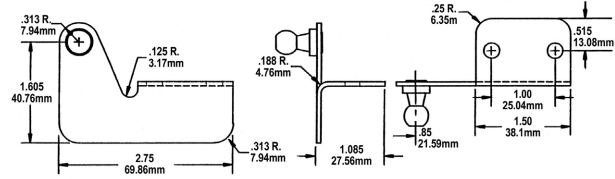

Part Number	Material
BR-11552	Steel Zinc Plate
BRX-11552	All Stainless Steel
BRX-11552-P	Electro Polished Stainless Steel

* 3mm thick material * .281 Dia. mounting holes
* 13mm ball stud

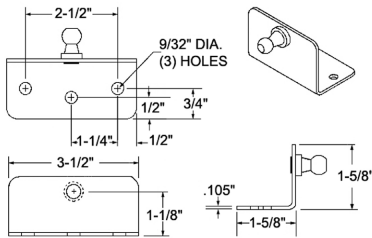

Part Number	Material
BR-11554	Steel Zinc Plate
BRX-11554	All Stainless Steel
BRX-11554-P	Electro Polished Stainless Steel

* 3mm thick material * .281 Dia. mounting holes
* 13mm ball stud

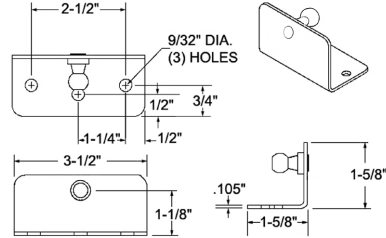

Part Number	Material
BR-1085	Steel Zinc Plate
BRX-1085	All Stainless Steel

* 2mm thick material * .188 Dia. mounting holes
* 10mm ball stud

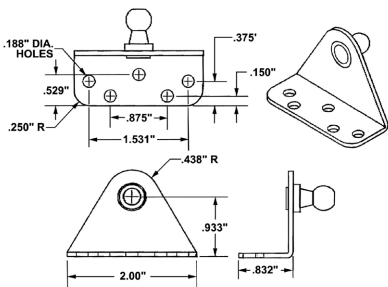

Part Number	Material
BR-11553	Steel Zinc Plate
BRX-11553	All Stainless Steel

* 3mm thick material * .281 Dia. mounting holes
* 13mm ball stud

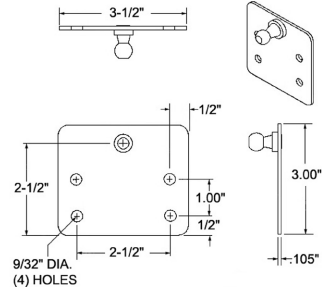

Part Number	Material
BR-1520	Steel Zinc Plate

* 2mm thick material * .200 Dia. mounting holes

Post diameter is 0.235 for 0.250 diameter blade end fitting.

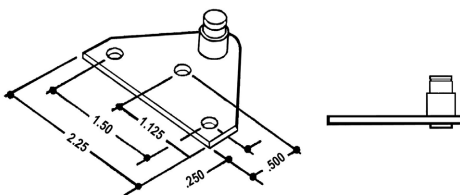

Part Number	Material
BR-1515	Steel Zinc Plate

* 2mm thick material * .200 Dia. mounting holes

Post diameter is 0.235 for 0.250 diameter blade end fitting.

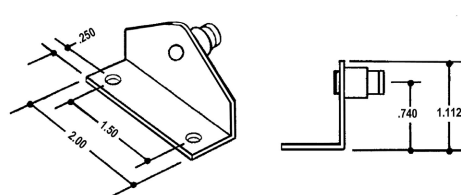

For those users who want to try various gas spring mounting configurations, we have created several hardware kits which all include various brackets, studs, nuts and safety clips. The kits are based on the size (6 x 15/8 x 18 or 10 x 22) and the material (nitride or stainless steel) of the gas spring. Please specify part number as indicated when ordering – example: M6x1Stainless. Individual part specifications can be found in pages 80 to 88.



Catalog No: M6x1 Nitride		Parts intended for use with 6x15 and 8x18 Nitrided Gas Springs	
Quantity	Part Number	Material	Description
2	BR-1010-BP	Steel/Black Painted	90 Deg. Bracket 0.74" height, 10mm ball stud, internal
2	EFPS90M1BP	Steel/Black Painted	10mm ball socket, 0.709" to center, safety clip required
2	SC-1006	Stainless Steel	Stainless Steel safety clip, used with 10mm system
2	BR-1020-BP	Steel/Black Painted	Flat bracket, with 10mm ball stud
2	BS-1005-BP	Steel/Black Painted	10mm ball stud, 1/2" hex, 5/16-18 thread
2	NU-1200-SS	Stainless Steel	5/16-18 nut
2	BR-1050-BP	Steel/Black Painted	90 Deg. Bracket 2.06" height, 10mm ball stud, internal

Catalog No: M6x1 Stainless		Parts intended for use with 6x15 and 8x18 Stainless Steel Gas Springs	
Quantity	Part Number	Material	Description
2	BRX-1010	300 Series SST	90 Deg. Bracket 0.74" height, 10mm ball stud, internal
2	EFPS90M1BP	300 Series SST	10mm ball socket, 0.709" to center, safety clip required
2	SC-1006	Stainless Steel	Stainless Steel safety clip, used with 10mm system
2	BRX-1020	300 Series SST	Flat bracket, with 10mm ball stud
2	BS-1005-SS	300 Series SST	10mm ball stud, 1/2" hex, 5/16-18 thread
2	NU-1200-SS	Stainless Steel	5/16-18 nut
2	BRX-1050	300 Series SST	90 Deg. Bracket 2.06" height, 10mm ball stud, internal

Catalog No: M8x125 Nitride		Parts intended for use with 10x22 Nitrided Gas Springs	
Quantity	Part Number	Material	Description
2	BR-11554	Steel/Zinc Plate	90 Deg. Bracket 1-1/8" hgt., 13mm ball stud
2	BR-11553	Steel/Zinc Plate	Flat Bracket, 13mm ball stud
2	SC-1008	Stainless Steel	Stainless Steel safety clip, used with 13mm system
2	BS-1007-BP	Steel/Black Painted	13mm ball stud, 1/2" hex, 5/16-18 thread, 0.68" long
2	NU-1200-SS	Stainless Steel	5/16-18 nut
2	EFPS100BP	Steel/Black Painted	13mm ball socket, 1.18" to center, safety clip required

Catalog No: M8x125 Stainless		Parts intended for use with 10x22 Stainless Steel Gas Springs	
Quantity	Part Number	Material	Description
2	BRX-11554	300 Series SST	90 Deg. Bracket 1-1/8" hgt., 13mm ball stud
2	BRX-11553	300 Series SST	Flat Bracket, 13mm ball stud
2	SC-1008	Stainless Steel	Stainless Steel safety clip, used with 13mm system
2	BS-1007-BP	300 Series SST	13mm ball stud, 1/2" hex, 5/16-18 thread, 0.68" long
2	NU-1200-SS	Stainless Steel	5/16-18 nut
2	EFPS100BP	Stainless Steel	13mm ball socket, 1.18" to center, safety clip required

We reserve the right to add, delete or modify components without notification.

All dimensions are nominal unless tolerance is stated.

1. With respect to goods purchased by Buyer from Seller ("Goods"), no contract exists until Buyer places order for delivery and such order is accepted by Seller's acknowledging receipt of the order, by Seller's commencement of work on the Goods ordered, or by Seller's shipment of the Goods, whichever occurs first. Any acceptance will be limited to the express terms contained on the face hereof. Additional or different terms in Buyer's form or any attempt by Buyer to vary in any degree any of the terms of this of this quotation shall be deemed material and are objected to and rejected, but this shall not prevent the formation of a contract between Buyer and Seller unless such variances are in the terms of the description, quantity, price or delivery schedule of the goods, and the order shall be deemed accepted by Seller without said additional or different terms.

2. All agreements are contingent upon strikes, accidents and other reasons for delay beyond Seller's control.

3. Where a separate charge is made for specially designed tools and dies, Seller will maintain such tools and dies without further cost to Buyer for the life of such tool or die so long as the part remains active and the design is not changed and Seller will not use such tools and dies for others without Buyer's permission, but Buyer acquires no right to remove any such tools or dies from Seller's factory.

4. Seller warrants to Buyer that the Goods purchased by Buyer from Seller shall be free from defects in material and workmanship. This warranty is the only warranty applicable to the Goods. THERE ARE NO OTHER WARRANTIES OF ANY KIND, EXPRESS OR IMPLIED, INCLUDING BUT NOT LIMITED TO THE IMPLIED WARRANTIES OF MERCHANTABILITY AND FITNESS FOR A PARTICULAR PURPOSE WHICH ARE HEREBY DISCLAIMED.

5. All Goods shall be inspected by Buyer when received and Seller shall not be liable for any defect unless notified in writing within 60 days after delivery.

6. Seller's liability for breach of warranty shall be limited solely and exclusively to repairing or replacing, at Seller's option, the defective Goods. In no event shall the liability of Seller for breach of any contractual provision relating to the Goods exceed the purchase price of the Goods quoted herein. In no event shall Seller be liable for any special, incidental or consequential damages arising out of Buyer's use or sale of the Goods or Seller's breach of any contractual provisions relating to the Goods, including but not limited to any loss of profits or production by Buyer. Any action resulting from any breach by Seller must be commenced within one year after the cause of action accrued.

7. Except to the extent caused by Seller's breach of warranty, Buyer shall indemnify and hold harmless Seller, its employees, officers and directors, and their respective successors and assigns, (collectively, "Indemnities") from and against any and all liability, damages, claims, causes of action, losses, costs and expenses (including attorneys' fees) of any kind (collectively, "Damages") arising out of injuries to any person (including death) or damage to any property caused by or related to the Goods or any negligent act or omission of Buyer, its employees or agents. Buyer shall indemnify and hold harmless each of the

Indemnities from and against any and all Damages, royalties and license fees arising from or for infringement of any patent by reason of any sale or use of the Goods or the manufacture of the Goods to Buyer's specifications or sample. Upon the tendering of any of the foregoing suits or claims to Buyer, Buyer shall defend the same at Buyer's expense. The foregoing obligations of Buyer shall apply whether Seller or Buyer defends such suits or claim.

8. Seller reserves the right to over and under ship by not more than 10% of specified quantity.



9. Small quantities are considered prototype quantities and cannot be returned since the cost of re-inspecting and handling them is generally higher than the value of the parts. Larger quantities may not be returnable depending on the ability to re-sell these parts within a reasonable time period. Special runs are not returnable. All returns must be authorized and an Authorization Number is required. Please contact our Customer Service at springsales@asraymond.com or by phone at 419-891-9292. Unauthorized returns will be returned at customer's expense. All authorized returns must be in their original packaging and labeling to insure lot control integrity. Parts cannot be altered or used in any fashion. Parts from separate lots cannot be mixed. A restocking fee will be charged to authorized returns. Additional charges may be required for re-inspection, cleaning and repackaging. Credit for damaged parts will not be issued. All returns will be shipped to the authorized return center pre-paid by sender. Actual credit issued will be for the quantity of acceptable parts at the original piece price, less the restocking charge, less the original freight and any other charges that are necessary to return the parts to a saleable condition.

10. Please note that all indicated prices on our web site are in US\$, and are for standard product shipped within the continental USA, including Alaska. For Canada orders, please call 1-800-263-4256 - Fax (419) 891-5979. For all other countries, please contact our Customer Service Department as indicated above or our International Distributors listed inside the back cover of this catalog.

The product data reported in this catalog represents typical values and is not intended to duplicate any specific customers test results. For product-specific AQL's, contact your ASR sales representative, as indicated tolerances may not apply. The catalog data presented is intended to be used as a guide only. It is not intended to be used to determine the suitability of the product for any specific customer application. AS Raymond strongly suggests that each customer thoroughly test the AS Raymond product to determine the actual suitability of the AS Raymond product in their specific application. The customer is responsible for determining the suitability of AS Raymond products in their applications. For more detailed information about these catalog products please contact your AS Raymond sales representative.

ASSOCIATED SPRING RAYMOND, A WORLD CLASS SUPPLIER

Our International Locations. Associated Spring Raymond products are distributed throughout the world. To locate our local distributor, see the listing below

AMERICAS	EUROPE & MIDDLE EAST	ASIA/PACIFIC
 <p>United States Associated Spring Raymond - SPEC Division Headquarters 370 W. Dussel Drive - Suite A Maumee, OH 43537 Phone: 419-891-9292 Fax: 419-891-9192 E-mail: springsales@asraymond.com Website: www.asraymond.com</p> <p>Brazil Associated Spring Raymond Rua Wallace Barnes 301A Distrito Industrial Caixa Postal 1288 13055-760 Campinas - SP Phone: 019 725 1083 Fax: 019 725 1084 E-mail: cfranco@asbg.com.br Website: www.asbg-spec.com.br</p> <p>Canada Associated Spring Raymond Toll Free: 800-263-4256 Phone: 814-664-7153 Fax: 419-891-5979</p> <p>Mexico Blvd. Carlos Salinas de Gortari No 1010 Ote Local G Esq. Blvd. San Francisco Col. Centro Apodaca, N.L. 66600 Phone: +52-81-81450680 Fax: +52-81-81450679 E-mail: ventas@asraymond.com Website: www.asraymond.com.mx</p>	 <p>United Kingdom Associated Spring SPEC Ltd. European Headquarters Unit 4 Grosvenor Business Centre Vale Park Evesham WR11 1GS Phone: 01386 443366 Fax: 01386 446669 E-mail: sales@assocspring.co.uk Website: www.assocspring.co.uk</p> <p>Czech Republic CECHO – Bohumil Cempírek Polnicka 151 591 01 Zdár nad Sázavou Phone/Fax: +420 566 629 367 E-mail: pruziny@cecho.cz Website: www.cecho.cz</p> <p>Denmark Sodemann Industrifjedre A/S Industrivej 21 DK – 8260 Viby J Phone: 45 86 72 00 99 Fax: 45 86 29 97 86 E-mail: sif@fjedre.dk Website: www.fjedre.dk</p> <p>Finland & Russia Meconet Oy Honkanummentie 8 FI-01260 Vantaa Suomi - Finland Phone: 00358 207 699300 Fax: 00358 207 699335 E-mail: reino.heikkinen@meconet.net Website: www.meconet.net</p> <p>France Resorts SPEC Batiment HERMES II Parc d'activités de Pissaloup BP 141 4 Rue Edouard Branly 78196 Trappes Cedex Phone: 01 30 68 63 63 Fax: 01 30 68 40 50 E-mail: info@ressortsspec.com Website: www.ressortsspec.com</p> <p>Germany Febrotec GmbH Frankfurter Strasse 76 D-58553 Halver Phone: 0049 2353 4866 Fax: 0049 2353 4301 E-mail: federn@febrotec.de Website: www.febrotec.de</p> <p>Hungary Biotek Kft 1165 Budapest Bokenyfoldi UT 104 Phone: 0036 1434 2900 Fax: 0036 1260 8635 E-mail: biotek@biotek.hu Website: www.biotek.hu</p> <p>Israel Delta Elkon Mechanical Products Ltd PO Box 8262 New Industrial Zone South Netaneya 42504 Phone: 00972 9865 8478 Fax: 00972 9865 8492 E-mail: natash@inergama.co.il Website: www.delta-elkon.co.il</p> <p>Italy Meter S.p.A Via s. Filippo, 1 13900 Biella Phone: 0039 015 23581 Fax: 0039 015 23646 E-mail: meter@meterspec.it Website: www.meterspec.it</p> <p>The Netherlands Amatec Jac. P. Thijsseweg 14 2408 ER ALPHEN AAN DEN RIJN Phone: 0031 172 43 93 59 Fax: 0031 172 44 03 13 E-mail: info@amatec.nl Website: www.amatec.nl</p> <p>Poland FCPK-BYTOW SP. Z.o.o Ul. Leborska 26 77-100 Bytow Poland Phone: 0048 59822 2026 Fax: 0048 59822 9703 E-mail: fcpc@fcpc.com.pl Website: www.fcpc.com.pl</p> <p>Spain Barnes Group Spain SRL La Peña 6 - Pab. 5 01013 Vitoria-Gasteiz Phone: 0034 945 147542 Fax: 0034 945 137655 E-mail: ventas@bgespana.com Website: www.bgespana.com</p> <p>Sweden EWES Stålfjäder AB Lundauagen 45 SE-330 10 Bredaryd Phone: 0046 370 86700 Fax: 0046 370 86249 E-mail: info@ewes.se Website: www.ewes.com</p>	 <p>Singapore Associated Spring Raymond Asia 15A Tuas Road Singapore 638517 Phone: (65) 6863 5636 Fax: (65) 6836 6325 E-mail: sales@raymondasia.com Website: www.raymondasia.com</p> <p>China Associated Spring Raymond (Shanghai) Co., Ltd 5th Floor (North) No. 4 Building No. 825 Ningqiao Road Pudong New District Shanghai 201206, China Phone: 86 21 5134 8111 Fax: 86 21 5134 8222 E-mail: sales@raymondasia.com Website: www.raymondasia.com</p> <p>Australia Hales Australia Pty Ltd 45 Woodlands Drive Braeside Victoria 3195 Phone: 61 3 9587 7700 Fax: 61 3 9587 7711 Email: info@hales.com.au Website: www.hales.com.au</p> <p>Hong Kong Shun Tai Trading Co. No 31-32, Block A, 2nd Floor Hoi Luen Industrial Centre 55, Hoi Yuen Road, Kwun Tong Kowloon, Hong Kong Phone: (852) 2797 0323 Fax: (852) 2343 7381 Email: info@shuntai.corp.com.hk Website: www.raymondasia.com</p> <p>India Star Circlips & Engineering Ltd B-24 MIDC Area Hingna Industrial Estate Nagpur – 440 016 India Phone: 0091 7104 236428 Fax: 0091 7104 237628 Email: sales@starcirclips.net Website: www.starcirclips.net</p> <p>Taiwan Spring Ming Co., Ltd No 8, Alley 30, Lane 207 Min-an Road., Hsin-Chuang City Taipei, Taiwan Phone: (886) 2 8201 4393 Fax: (886) 2 2202 0395 Email: smc@springming.com Website: www.raymondasia.com</p>

Associated Spring-Raymond



United States

OHIO

370 W. Dussel Drive - Suite A
Maumee, OH 43537
Phone: 419.891.9292
Fax: 419.891.9192

CALIFORNIA

6180 Valley View Avenue
Buena Park, CA 90620
Phone: 714.523.5125
Fax: 714.523.5120

Canada

Associated Spring Raymond
Toll Free: 1.800.263.4256
Phone: 814.664.7153
Fax: 419.891.5979

**For the center nearest you, call toll free:
In the continental U.S.: 1.800.872.7732
In Canada: 1.800.263.4256**

**On the Internet
www.asraymond.com**

Associated Spring
RAYMOND

 A business of BARNES GROUP INC